



OPERATION MANUAL

UniPrint121EB SSLAW/SSHSLA Operator Manual

(Original Instructions)

Innovative Machine, Inc.

imisolutions.com

Copyrights

Any unauthorized reproduction of the contents of this document, in part or whole, is strictly prohibited.

Limitation of Liability

Innovative Machine, Inc. (IMI) makes no representations or warranties of any kind regarding this material, including, but not limited to, implied warranties of merchantability and fitness for a particular purpose. IMI shall not be held responsible for errors contained herein or any omissions from this material or for any damages, whether direct, indirect, incidental, or consequential, in connection with the furnishing, distribution, performance or use of this material. Specifications and contents in this document are subject to change without notice.

Document Name	UNIPRINT121EB SSLAW/SSHSLA
Language	Operator Manual
Revision	English (Original Instructions) 8 – 9/2023



Innovative
Machine, Inc.

6115 NW 123rd Place
Gainesville, FL 32653
(386) 418-8880

Table of Contents

Introduction.....	3
Specifications.....	5
Important Safeguards.....	6
Residual Risks.....	6
Precautions for Handling, Installation, and Use.....	7
Foreseeable Misuse.....	8
Noise.....	8
Limitations of Use.....	8
Lifting and Handling.....	9
Definition of Components.....	10
Component Overview.....	10
Print Engine Detail.....	11
Identification Tag.....	12
Component Details.....	13
Roll Feed and Low Label Sensor.....	13
Label Guide.....	14
Gap Sensor.....	15
Print Head Pressure Switch.....	16
Extend Blow Head.....	17
Dancer Arm.....	18
Take Up Spool.....	19
Installation and Start-Up.....	20
Installation and Commissioning.....	20
Existing Machine Replacement.....	20
Start-up Steps.....	21
Label Alignment.....	25

Proper Label Feed Position	26
New Machine Checklist	27
General Maintenance	28
Proper Cleaning Supplies	28
Frequency of maintenance	28
Cleaning (recommended daily)	28
Decommissioning and Disposal	29
Troubleshooting/Support	30
Spare Parts	31
UniPrint121EB SSLAW Spare Parts List	31
UniPrint121EB SSHSLA Spare Parts List	32
Support Links for All UniPrint Models	33

Introduction

The UniPrint121EB SSLAW and UniPrint121EB SSHSLA machines were designed to replace the previous UniPrint109/116 SSLAW and UniPrint116 SSHSLA respectively. The UniPrint121EB SSLAW will use the new 10in. SSLAW stand, which will need to be installed in place of the previous 12in. stand. All other set up and installation processes will need to be coordinated with UPS BaSE personnel.

General use of the UniPrint121EB SSLAW and UniPrint121EB SSHSLA models are to apply a paper label that is 63.5mm (2.5”) wide x 44.45mm (1.75”) long, with a 47.5mm (1.870”) pitch and 66.68mm (2.625”) liner width. Tolerances on the label are .25mm (.009”). Nominal label thickness is .1mm (.004”) with the liner of .05mm (.002”) for an overall thickness of .15mm (.006”).

The UniPrint121EB SSLAW/SSHSLA will apply a label to the top of a package from 25.4mm (1”) to 393mm (10”) away. Package sizes will be a minimum of 50.8mm (2”) wide with a max height of 393mm (10”).

All UniPrint121EB SSLAW/SSHSLA models will be able to provide the following:

- Report conditions (like machine error, offline, home position, low label, etc.) through Input/Output (I/O) to the customer control panel.
- I/O devices are powered from the contained Sato Engine’s 24VDC supply.
- All sensors must be the PNP type.
- Allow for label stock replenishment in approximately 60 seconds.
- Label placement accuracy can be less than or equal to +/- 6.35mm at a max distance of 50.8mm (2”) from the centerline on the blow head.
- RFID label enabled.
- A status indicator “light tree” is located on the machine. The indicator contains an audible alarm and a multicolor light. This is controlled by both the SSLAW/SSHSLA itself as well as the customer control panel.
- Apply labels at a rate up to 355mm/sec or 4112 labels per hour per machine.



Both the UniPrint121EB SSLAW and the UniPrint121EB SSHSLA are top apply machines. This means that the machine applies a label to the top of a package. As the package advances under the machine, the actuator will extend, if needed, to apply the printed label using compressed air.

These two models are essentially the same with only a few differences. This manual will display the SSLAW in the visual aids, but the information will also apply to the SSHSLA.

121EB SSLAW



121EB SSHSLA











Specifications

	UniPrint121EB SSLAW	UniPrint121 SSHSLA
Dimensions and Weight		
Width	27.812" (706.42 mm)	27.812" (706.42 mm)
Height	19.5" (495.3mm)	19.5" (495.3mm)
Depth	21" (533.4mm)	21" (533.4mm)
Weight	33.57kg (74lb)	34.93kg (77lb)
Power Supply		
Input Voltage	AC 100 V - 240 V ±10% DC 24v Both supplied through Harting Connector	AC 100 V - 240 V ±10% DC 24v Both supplied through Harting Connector
Frequency	AC – 50-60 Hz	AC – 50-60 Hz
Power Consumption	AC – 7.5 amps DC – 2 amps	AC – 7.5 amps DC – 2 amps
Pneumatics		
Min/Max Pressure	5.17bar(75psi)/5.51bar(80psi)	5.17bar(75psi)/5.51bar(80psi)
Min Volume	11.72m3/h (6.0cfm)	11.72m3/h (6.0cfm)
Environmental Conditions (Without Media)		
Operating Temperature	-5 to 40 °C (23 to 104 °F)	-5 to 40 °C (23 to 104 °F)
Storage Temperature	-20 to 60 °C (-4 to 140 °F)	-20 to 60 °C (-4 to 140 °F)
Operating Humidity	15 to 85% RH (Non-condensing)	15 to 85% RH (Non-condensing)
Storage Humidity	15 to 90% RH (Non-condensing)	15 to 90% RH (Non-condensing)

Important Safeguards

Residual Risks

CE versions of the UniPrint121EB SSHSLA/SSLAW uses a variety of pictographic symbols. These symbols show the safe and correct operation of the machine and how to prevent injury to others and property damage. The symbol explanations are as follows:

	Electrical Shock / Electrical Hazard
	Lock Out / Electrical Power. Before any maintenance of the machine is to be done, the Electrical Lock-Out Tag-Out should be used.
	Lock Out / Pneumatic. Before any maintenance of the machine is to be done, the Pneumatic Lock-Out Tag-Out should be used.
	Hand Entanglement / Belt Drive Hazard
	Please read and understand all manuals prior to use.
	Two-person lift. Machine requires two people to always handle.
	Pinch Point. Do not put any hands/fingers under or in between blow head.
	This machine is UKCA and CE Certified in accordance with the applicable UK & EU Directives and BS EN Standards, current at the time of certification; any modification to this machine, without the prior consent of the manufacturer, may invalidate the compliance of the machine.

Precautions for Handling, Installation, and Use

This section describes how to safely operate the UniPrint121EB SSLAW/SSHSLA machine. Be sure to read and understand all instructions carefully before you install and/or use the machine.

- Place the machine on the stand provided.
- Do not place objects on the machine.
- Do not place containers filled with liquid on the machine. If any liquid spills onto or into the machine, immediately power off and disconnect power. If you operate the machine under these conditions, it could cause a fire, electric shock or malfunction.
- Do not place objects inside the machine. If a foreign object gets inside the machine, immediately power off and disconnect the power.
- Use only specified voltages. Using voltages outside specified ranges could cause a fire, electric shock or malfunction.
- Always connect the machine to electrical ground. Not using the grounding wire could cause an electric shock.
- Do not share the machines power source with other electrical devices, doing so could cause power fluctuations and performance issues.
- Do not break, change, overly bend, twist, place heavy objects on or pull the 16 pin harting interface cable. If the cable becomes damaged, contact Innovative Machine Inc. or the Technical Support Center. Using the cable in this condition could cause a fire, electric shock or malfunction.
- If the machine has been dropped or broken, immediately power off and disconnect the power. Using a damaged machine could cause a fire, electric shock or malfunction.
- Do not use the machine if anything is unusual about it, i.e., smoke, unusual smells, or broken parts. Continuing to use the machine in this state, could cause a fire, electric shock or malfunction.
- Do not disassemble or modify the machine. Doing so could cause a fire, electric shock or malfunction.
- Do not place the machine in a location subject to water and/or oil. Water and/or oil entering the machine may cause a fire, electric shock, or malfunction.

Foreseeable Misuse

To prevent damage to the machine and protect the customer from harm:

- Do not climb on the machine for any reason. It is not designed for this purpose. Safe means of access have been provided by either the Manufacturer and/or the End User.
- Do not operate the machine unless trained and authorized to do so. “Read Manual before operating” decals are affixed at Control Stations.
- Do not use the machine outdoors. It is rated for indoor use only.
- Do not operate in an explosive atmosphere, i.e., ATEX environment. It is not rated for this purpose.

Noise

The maximum corrected noise levels recorded for this machine was 78.3 db(A) and 81.3 db(C). There is no requirement for hearing protection to be worn in the vicinity of this machine, unless required as an End User site policy.

Limitations of Use

The UniPrint121EB SSLAW/SSHSLA should always be inside for operation and storage. The machine should only be operational when temperatures are between -5 to 40 °C (23 to 104 °F) and stored in temperatures between -20 to 60 °C (-4 to 140 °F). The machine should be in an environment where the humidity is between 15 to 85% RH (Non-condensing).

Only trained personnel should operate and conduct maintenance on the UniPrint121EB SSLAW/SSHSLA machine. All personnel should read and comprehend the operation manual in its entirety before operating or conducting any maintenance on the machine.

Lifting and Handling

The UniPrint121EB SSLAW/SSHSLA machines exceed the weight recommended for one person to move or handle (SSLAW = 33.57kg and SSHSLA = 34.93kg). Two people are required when handling the machine at all times. Handling involves installation, removal or replacement for service.

The UniPrint family of label machines must be handled correctly to not damage certain components.

- **DO NOT** use the Light Tree (A), Regulator (B), Actuator (C), or Dancer Arm (D) when moving or positioning the equipment.
- The machine **MUST** be picked up with a person on each side of the frame while using the designated handles (E).
- Both the UniPrint121EB SSLAW and SSHSLA are not mounted from the factory to the stand. The stand is shipped and mounted separately.
- The UniPrint121EB SSLAW is held on a stand with 2 brackets. The SSHSLA is mounted to the stand with (2) Y Mounts and (6) 1/4-20 nuts to secure it in place.

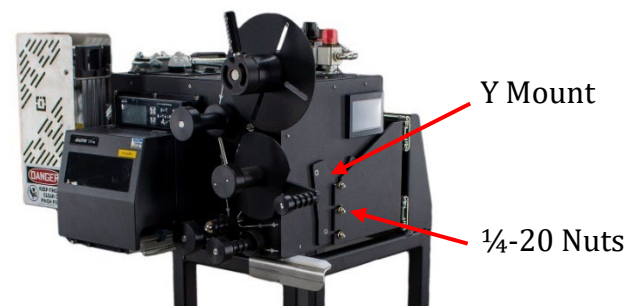
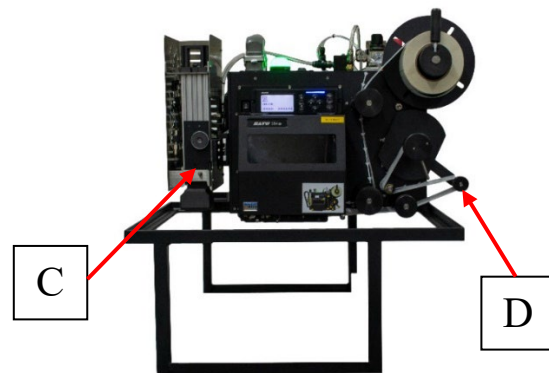
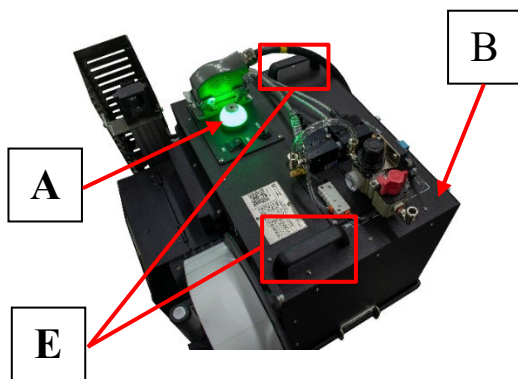

Definition of Components

Component Overview

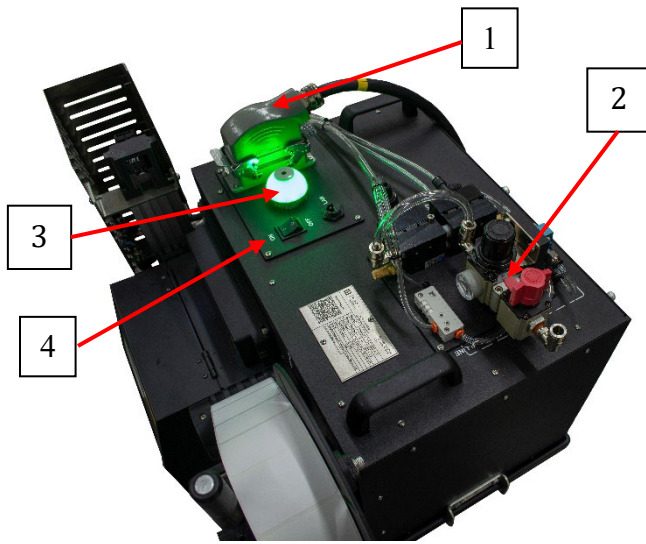

1	Harting Connector
2	Regulator/Disconnect
3	Light Tree
4	Power Switch
5	SATO LCD Display
6	SATO S84-EX OR S84NX Print Engine
7	Actuator Assembly
8	Blow Head
9	Stand
10	Roll Feed
11	Take Up Hub
12	Dancer Arm
13	Idle Roller
14	Pinch Rollers

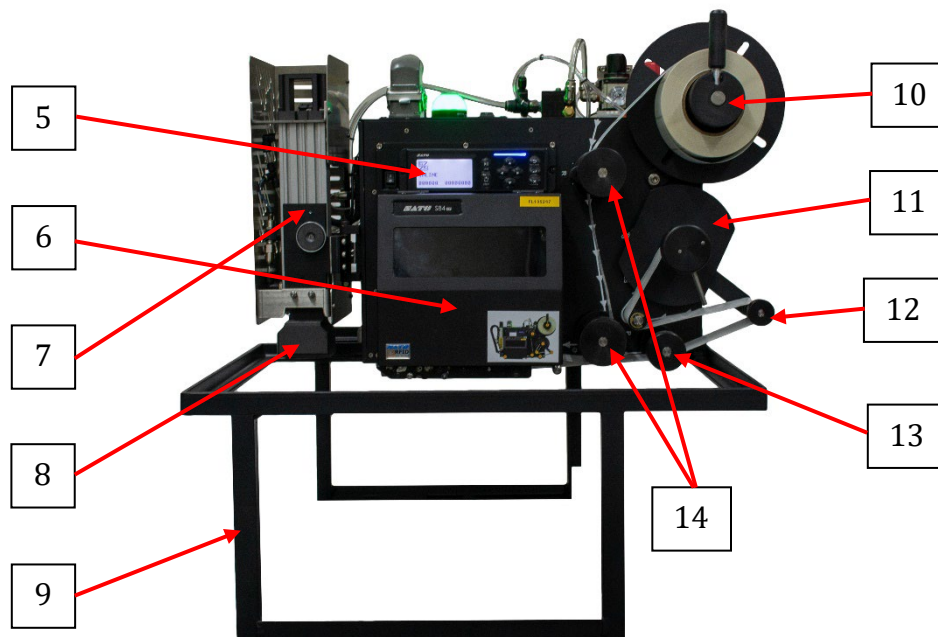

Print Engine Detail

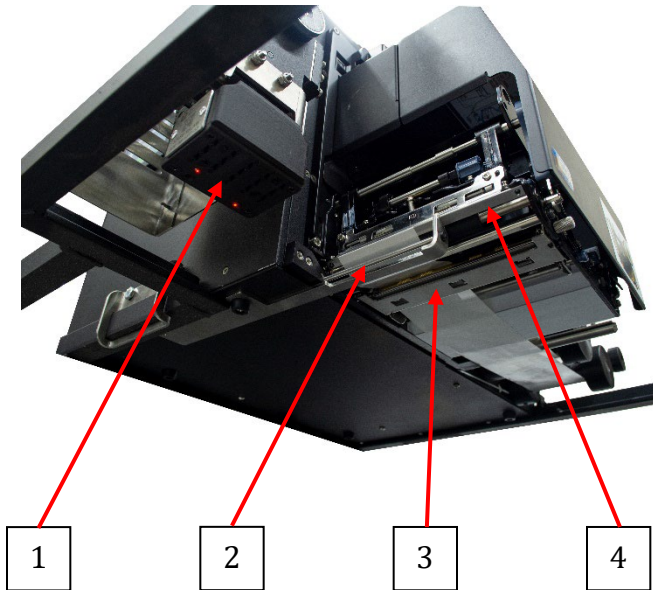

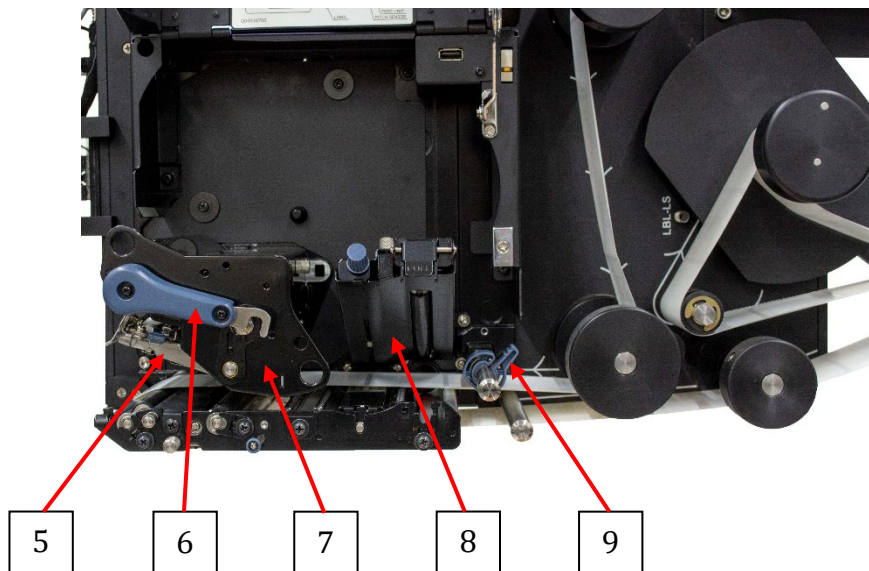

1	Blow Head
2	Air Assist Rod
3	Pressure/Knurl Roller Assembly
4	Dispense/Peel Bar
5	Print Plate/Head
6	Latch for Print Plate/Head
7	RFID Insert
8	Gap Sensor
9	Label Guide





Identification Tag



All identification tags will list the model type, frame serial number, machine info, and Innovative Machine contact information. The tag includes a QR code to access the UniPrint121EB SSLAW/SSHSLA support webpage. This webpage includes helpful documents, videos for routine maintenance, interactive images to reference replacement parts, and more.



Non-CE Version

 Innovative Machine, Inc. +01 386-418-8880 sales@imisolutions.com		6115 NW 123rd Place Gainesville, FL 32653 USA	
Scan for Support 	Model: Uniprint121EB SSLAW		
	Serial Number : IMI - 1030 - 14		
	Power Supply: 110/240 Vac, Single Phase 50/60Hz + PE		
	Weight/Mass: 74 lbs. / 33.6 Kgs		
	Full Working Load: 6 Amp		
	SCCR: 5KA		
	Electrical Drawing #: 091416-914 through 091416-1448		
	Year of Manufacture: 2022		

CE Version

 Innovative Machine, Inc. +01 386-418-8880 sales@imisolutions.com		6115 NW 123rd Place Gainesville, FL 32653 USA	
Scan for Support 	Manufacturer Info:		
	Machine Type: Printer and Label Application		
	Model: Uniprint121EB SSLAW		
	Serial Number: IMI - 1030 - 14		
	Power Supply: 120/230 VAC, Single Phase, 50/60 Hz + PE		
	Full Working Load: 7.5 Amp		
	Electrical Drawing #: 090822-002 to 030		
	SCCR: 5 Kv/A		
	Weight: 37 Kg / 82 lbs		
	Year of Manufacture: 2022		
European Authorized Representative:		Hold Tech Files Ltd, Dun Iséal, Newtown Gausmill, Ferrybank, Waterford, X91F63S Republic of Ireland	
			

 Innovative Machine, Inc. +01 386-418-8880 sales@imisolutions.com		6115 NW 123rd Place Gainesville, FL 32653 USA	
Scan for Support 	Model: Uniprint121EB SSHSLA		
	Serial Number : IMI - 1040 - 18		
	Power Supply: 110/240 Vac, Single Phase 50/60Hz + PE		
	Weight/Mass: 74 lbs. / 33.6 Kgs		
	Full Working Load: 6 Amp		
	SCCR: 5KA		
	Electrical Drawing #: 091416-914 through 091416-1448		
	Year of Manufacture: 2022		

 Innovative Machine, Inc. +01 386-418-8880 sales@imisolutions.com		6115 NW 123rd Place Gainesville, FL 32653 USA	
Scan for Support 	Manufacturer Info:		
	Machine Type: Printer and Label Application		
	Model: Uniprint121EB SSHSLA		
	Serial Number: IMI - 1004 - 18		
	Power Supply: 120/230 VAC, Single Phase, 50/60 Hz + PE		
	Full Working Load: 7.5 Amp		
	Electrical Drawing #: 090822-002 to 030		
	SCCR: 5 Kv/A		
	Weight: 37 Kg / 82 lbs		
	Year of Manufacture: 2022		
European Authorized Representative:		Hold Tech Files Ltd, Dun Iséal, Newtown Gausmill, Ferrybank, Waterford, X91F63S Republic of Ireland	
			

Component Details

Roll Feed and Low Label Sensor

The roll feed allows the labels to be properly mounted/fed through the machine and maintains proper tension on the label feed. If excess or lack of tension occurs, labels can jam or feed improperly causing label application problems. To load the roll stock, lift the roll feed handle up then towards your person.

The low label sensor is an I/O connection to UPS's control PLC. This sensor will detect when the roll stock is low.

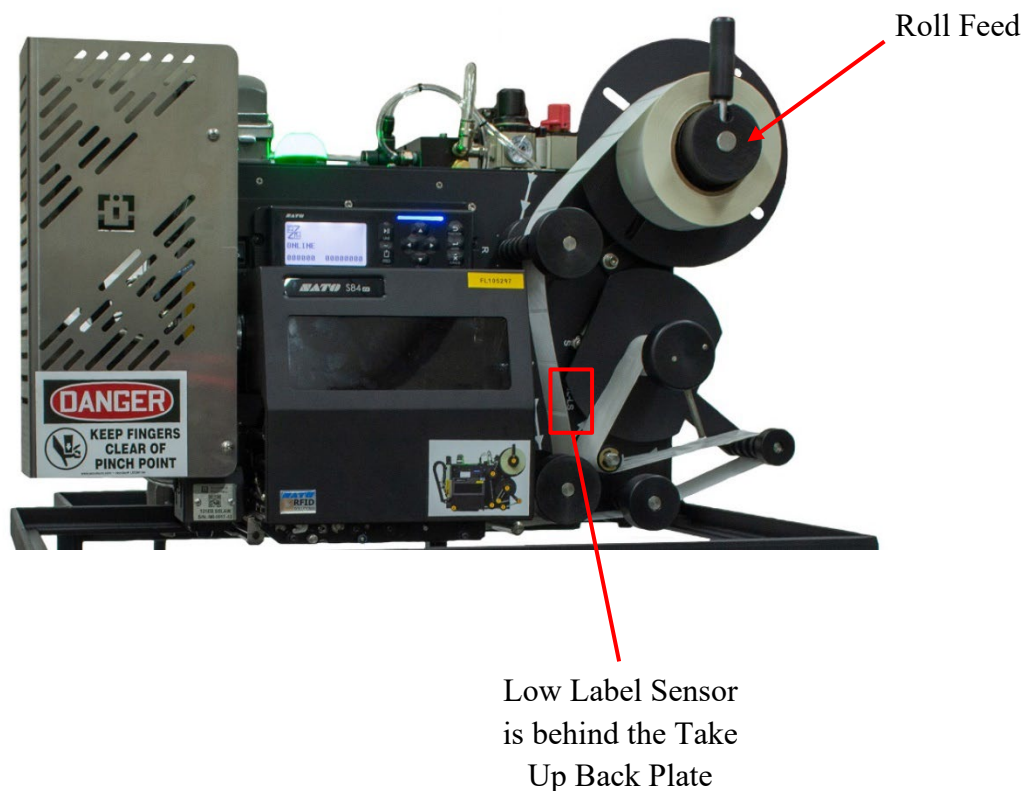

Label Guide

The label guide is a blue tab inside the S84 print engine that prevents the label liner from moving off track of the normal label feed path. If the guide is not touching the label liner, labels can get off track and result in labels bouncing. Verify the label guide is free of residue to prevent label application problems.

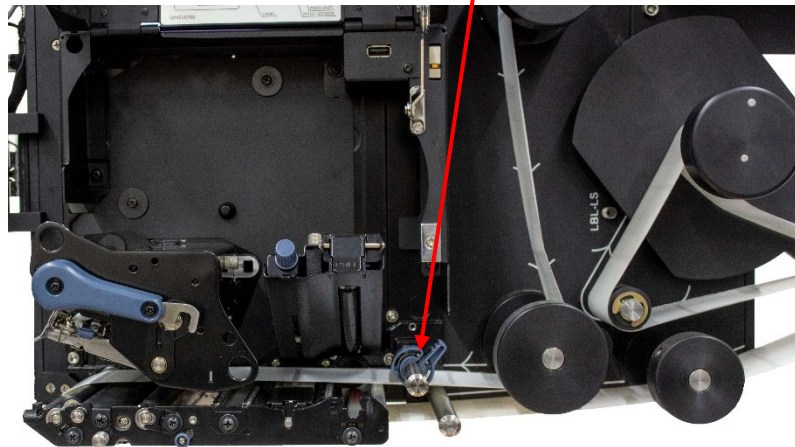
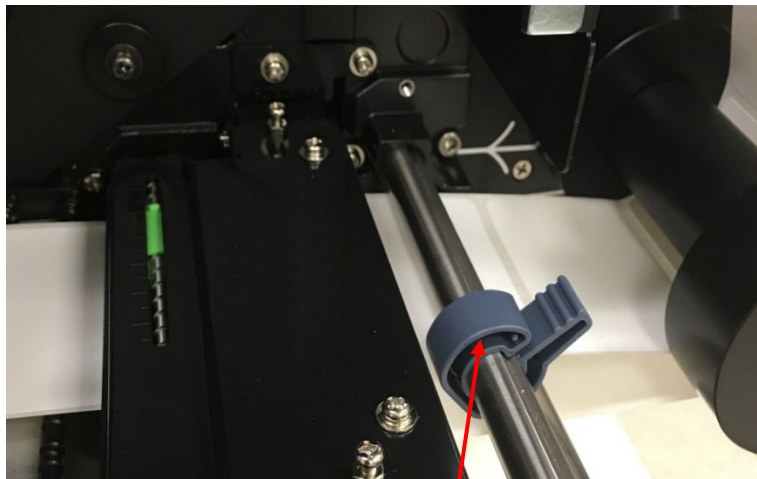

Gap Sensor

The gap sensor provides the S84 print engine with feedback on the status of labels being fed through the printer. As the labels travel through the engine, this sensor detects the labels and the gaps between the labels to ensure the availability of material to print. When the sensor is dirty it can no longer properly detect the labels and will cause a “Labels Out” fault and/or multiple blank labels to be fed at once. To correct this issue, clean the gap sensor and rollers.

If cleaning the gap sensor does not help, then you may have to calibrate the gap and I-mark sensors.

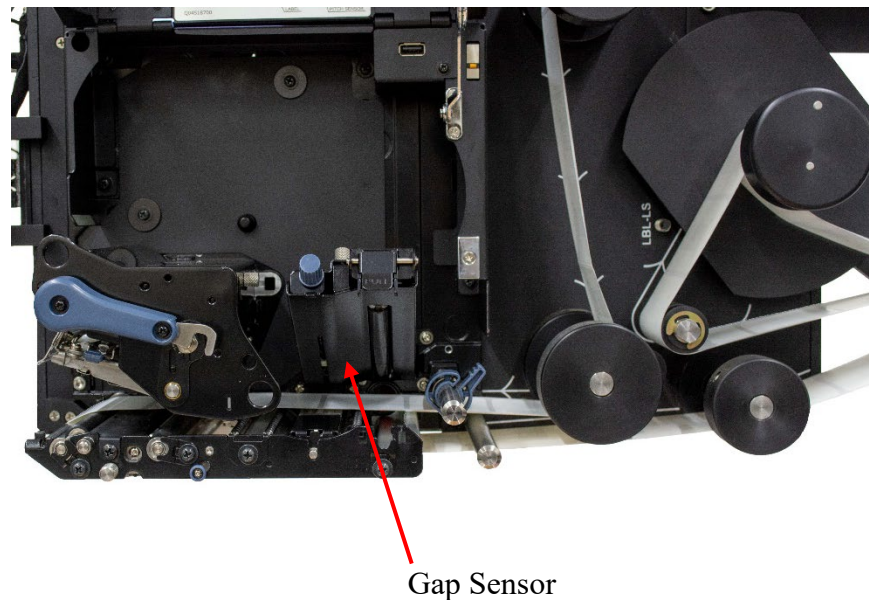

Print Head Pressure Switch

The pressure switch provides the ability to increase the pressure the print head applies to the label stock. This affects the ability of the print plate to properly contact the label for printing. The label stock UPS utilizes requires the least amount of pressure due to its thickness (4mils). If the switch is increased to anything other than 1, an increase in the tension on the labels could occur causing label feed issues.

Having the pressure switch set at 2 or 3 will cause premature wear on the print head and shortens the life of this component.

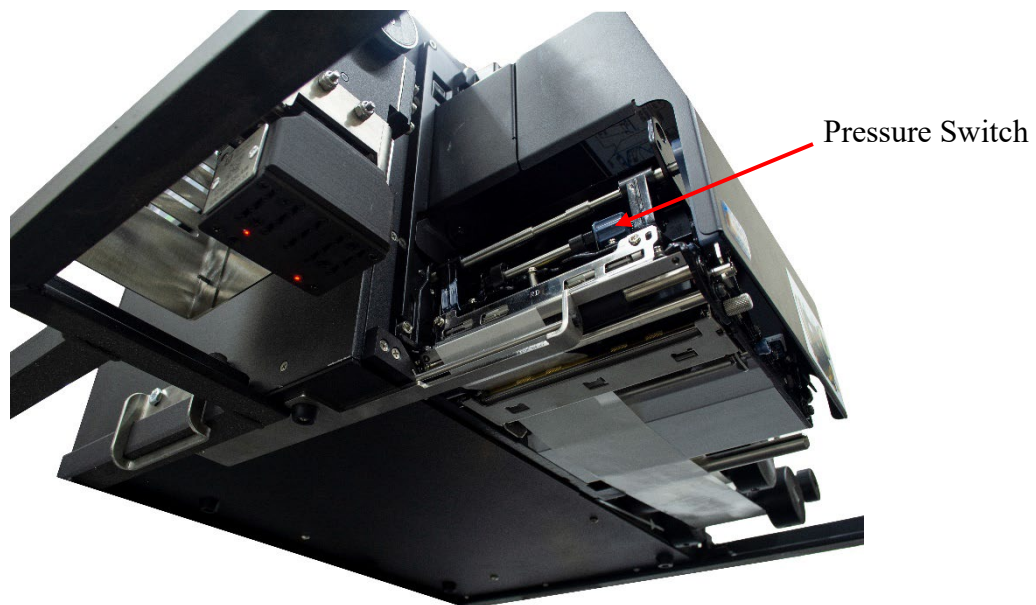

Extend Blow Head

The pickup mechanism, referred to as the vacuum plate, is operated by on-board pneumatics to create vacuum when the label is dispensed. This holds the label onto the head until it is applied using a blast of compressed air.

The label detect photo eye detects when a label is on the blow head. This photo eye is connected to the LBL amplifier. Its value should always be set to 100. If this photo eye is dirty, the EB SSLAW/SSHSLA system will experience either false “Label on Blow Head” faults or will not blow the label onto the package. Cleaning the photo eye typically solves both issues.

The package detect photo eye detects how close a package is to the blow head. This photo eye is connected to the PKG amplifier. The default setting is 150. If the photo eye is damaged or dirty, the arm may hit the package or may not extend.

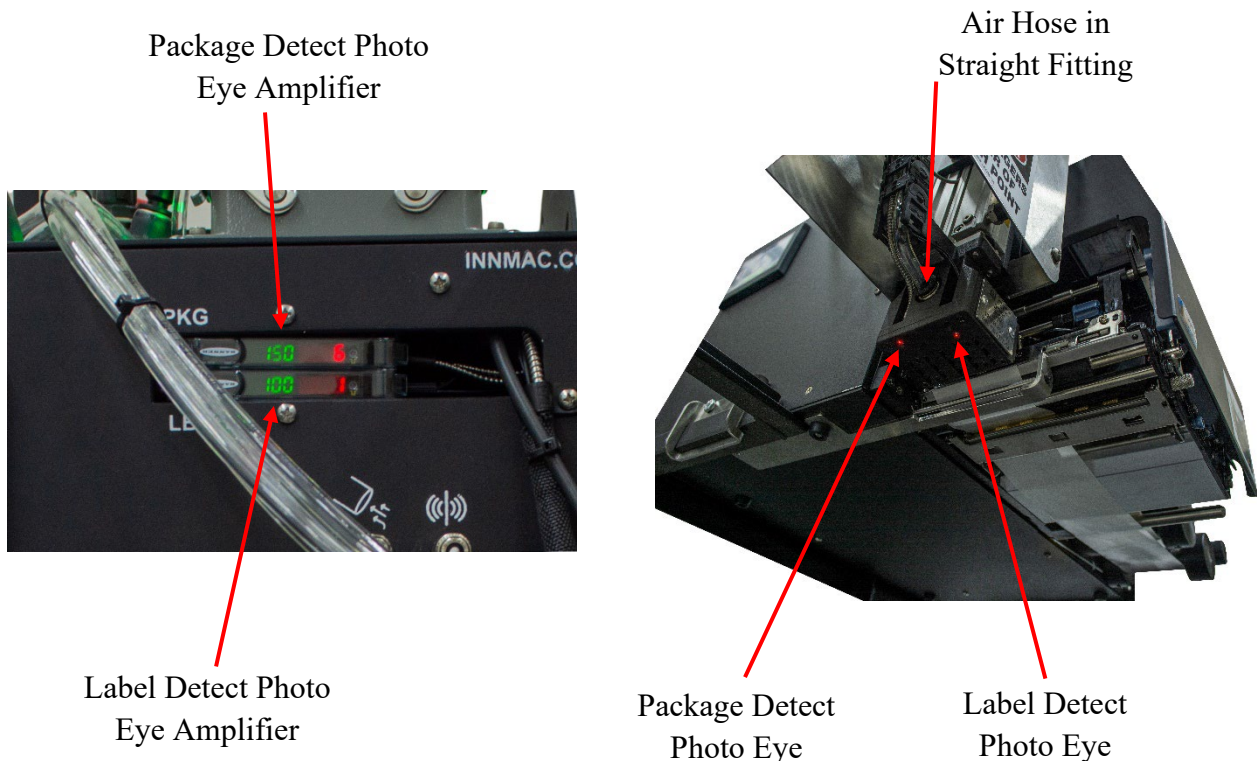

Dancer Arm

The dancer arm provides constant tension on the label liner to prevent a jam in the label feed path. The dancer arm controls when the take up spool rotates to take up any slack in the label liner. The dancer arm should move/spin freely. The photoeye inside the machine frame detects the presence of the dancer arm as it moves across. As the dancer arm travels towards the furthest point the photoeye engages the take-up spool. Once the dancer arm returns to its neutral position the photoeye dis-engages the take-up motor. If the photoeye fails, the take-up spool drive will not run. Also, if the S84 print engine door is open, the take up will turn off.

To test the photoeye remove the liner from the take up spool and manually move the dancer arm. Verify the LED on the photoeye is changing states from amber to black. If not, then the photoeye needs to be replaced.

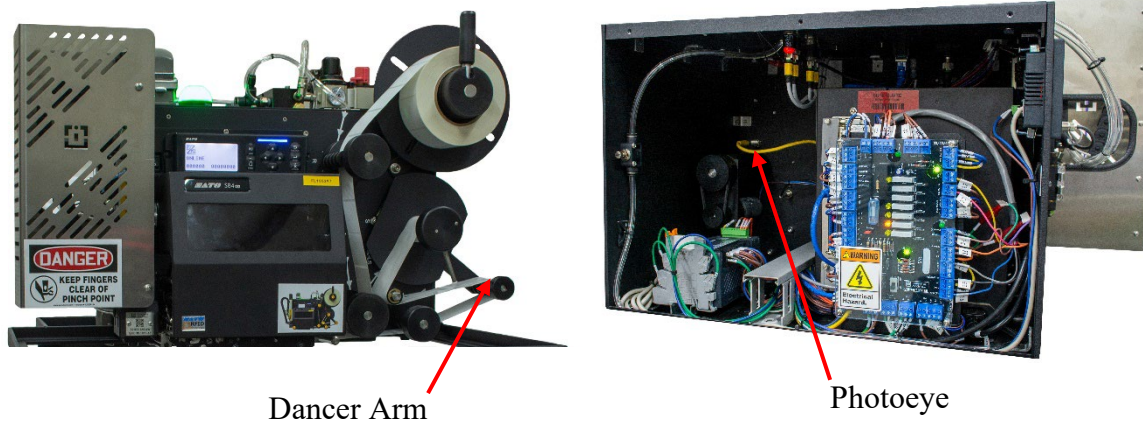

Take Up Spool

The take up spool provides the machine with a simple way to retrieve and store all used label liner and keep proper tension on the feed system. The motor for the take up spool is controlled by the dancer arm and should only be engaged while the dancer arm is extended past its resting position. If the drive belt is worn or the motor fails, the take up spool will not respond to the dancer arm.

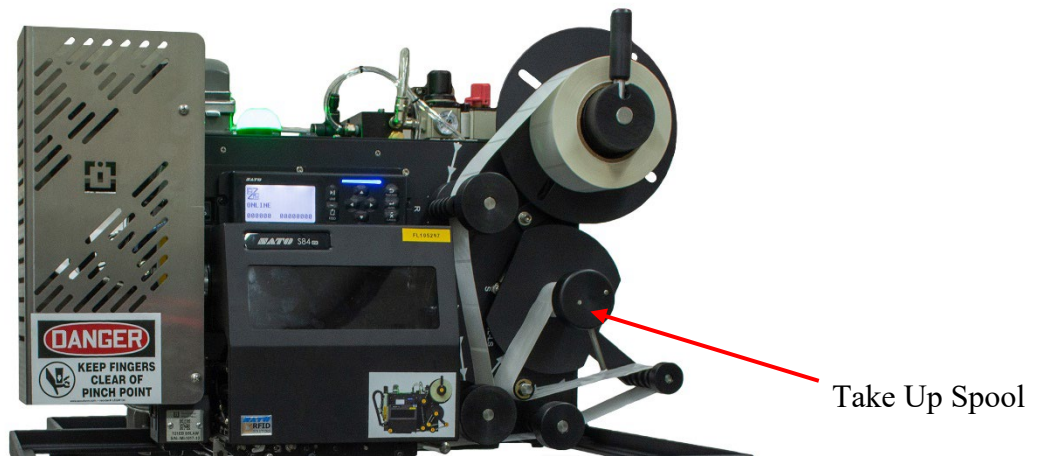

Installation and Start-Up

Installation and Commissioning

Once installed onto the stand, the 16-pin harting connector can be plugged in and secured to the harting base. The input voltage will be supplied through the harting connector with 100 – 240V \pm 10%, 50-60Hz AC. DC power is supplied by the internal Sato Print Engine. The power consumption of AC is 7.5 amps while DC usage is 2 amps.

The minimum pneumatic supply should be 5.17bar (75 psi) and maximum pneumatic supply should be 5.51bar (80psi). The minimum pneumatic volume is 11.72 m³/h (6.0 cfm).

Existing Machine Replacement

The UniPrint121EB SSLAW and UniPrint121EB SSHSLA machines were designed to replace the previous UniPrint109/116 SSLAW and UniPrint116 SSHSLA respectively. The UniPrint121EB SSLAW will use the new 10in. SSLAW stand, which will need to be installed in place of the previous 12in. stand. All other set up and installation processes will need to be coordinated with UPS BaSE personnel.

Start-up Steps

1. Make sure the harting, air in and LAN connections are attached.
2. Make sure the air disconnect is open (label should display SUP and regulator will show pressure).
3. Make sure the regulator is reading 80psi. If not, adjust accordingly.

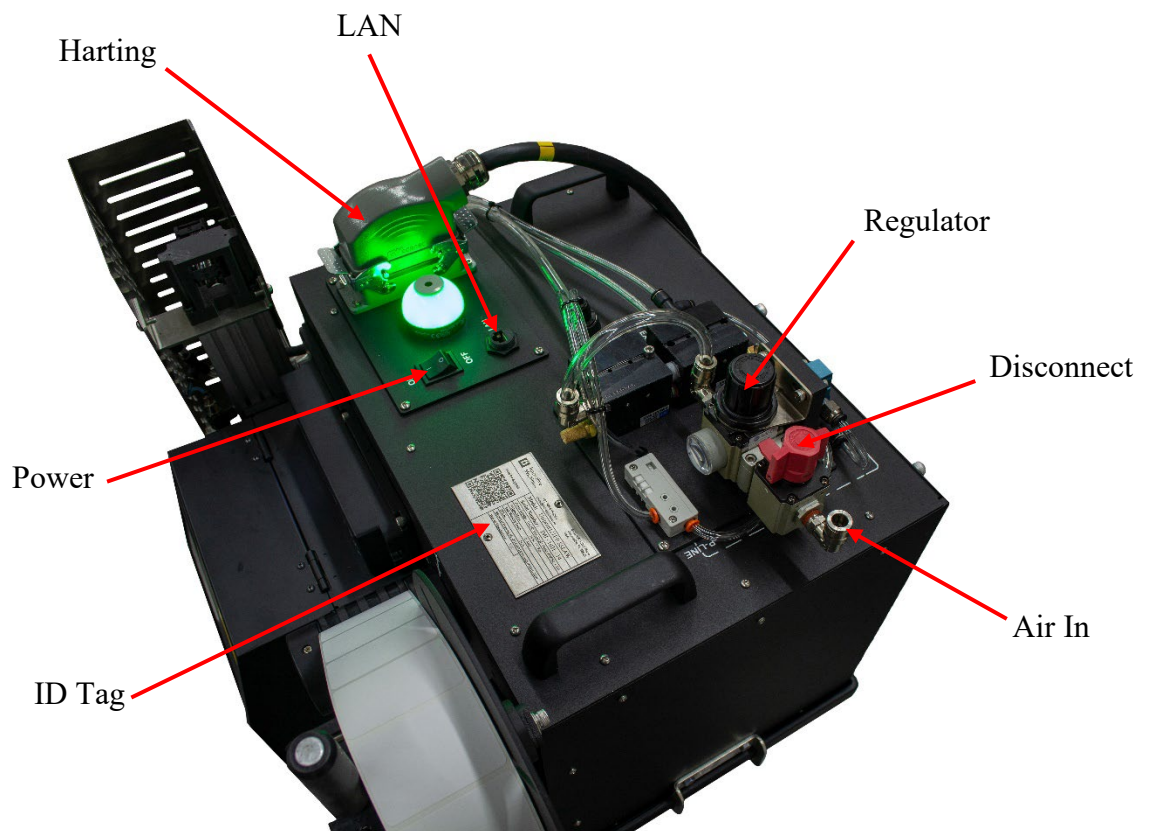

4. Load the labels, following the path printed on the main plate and represented in the pictures on the front of the machine, making sure not to miss any pinch or standard rollers.

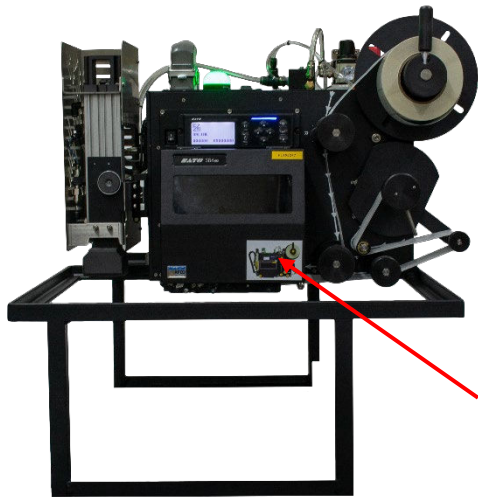

Follow Path
Shown on
Sticker

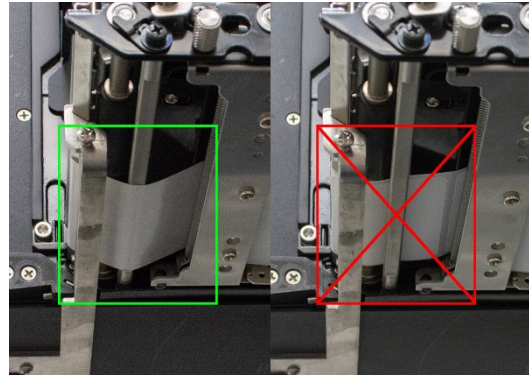

5. Using the power switch, turn on the machine. If the Sato print engine is not powered up, use its power switch to turn it on.
6. When powered up, the HMI should look like this. In this mode the actuator is disabled.

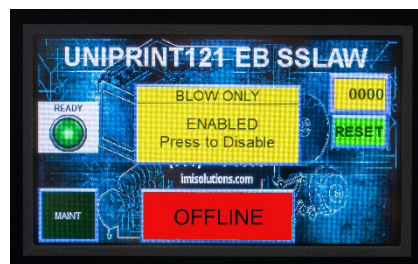

7. Press the “OFFLINE” button. The actuator will withdraw a slight amount (~ ½”) and the HMI should look like this:

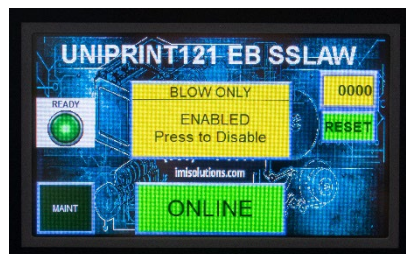

- Continue with this step if this process is being performed after a power on, otherwise skip to step 9.

Because the machine in “BLOW ONLY” mode, you need to run a few labels to make sure they are registering correctly on the blow head.

S84-ex

- Press the “LINE” key on the S84-ex print engine. “OFFLINE” should be shown on the display.
- On the UPS Control Panel, turn the maintenance/pre-trip switch to “ON”.
- Place your hand or a package in front of the blow head, press the “FEED” key on the print engine.
- If multiple labels dispense, remove them from the blow head.
- Press the “FEED” key. Each time the “Feed” key is pressed a label should be dispensed on the blow head and blown onto your hand or package.
- Make sure to run at least five labels without any problems.
- Press the “LINE” key on the print engine. “ONLINE” should be shown on the display.
- Turn the maintenance/pre-trip switch to “OFF”.

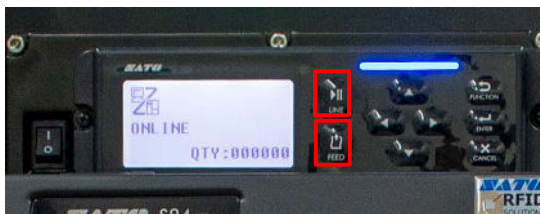

S84NX

- Press the left rectangular button. “Offline” should be shown on the display.
- On the UPS Control Panel, turn the maintenance/pre-trip switch to “ON”.
- Place your hand or a package under the blow head and press the right rectangular button.
- If multiple labels dispense, remove them from the blow head.
- Press the right rectangular button. Each time the button is pressed a label should be dispensed on the blow head and blown onto your hand or package.
- Make sure to run at least five labels without any problems.
- Press the left rectangular button. “Online” should be shown on the display.
- Turn the maintenance/pre-trip switch to “OFF”.



9. On the HMI, press the “BLOW ONLY” button. The HMI display should look similar to this:

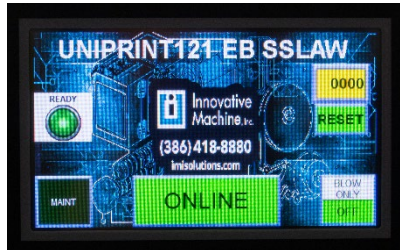

At this point the machine is in normal run mode. UPS controls the timing for all processes of label application: sending of label data, dispensing the label onto the blow head (SSLAW only), and application of the label onto the package. If present, the label counter will track the number of labels dispensed since the machine was powered up. You can reset the count by pressing “RESET” right below the counter on the HMI.

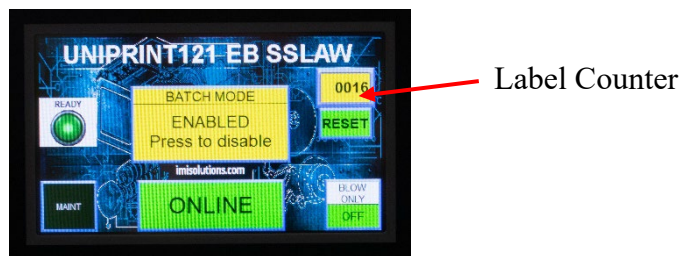

Label Alignment

Adjustments to label tracking is only needed when the label is consistently being fed onto to blow head at an angle.

Once an adjustment to the tracking has been made, the label should be centered on the blow head face plate and in alignment with the label detect photo eye. For example, the label below is perfectly aligned with the red line.

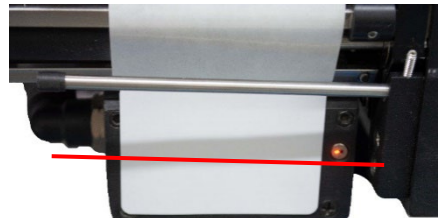

The label should always apply straight down from the center of the blow head. The actuator arm can be adjusted three different ways: up/down, outwards, and left (with shim). The adjustment is dependent on the way the label is fed onto the blow head and applied to a package.

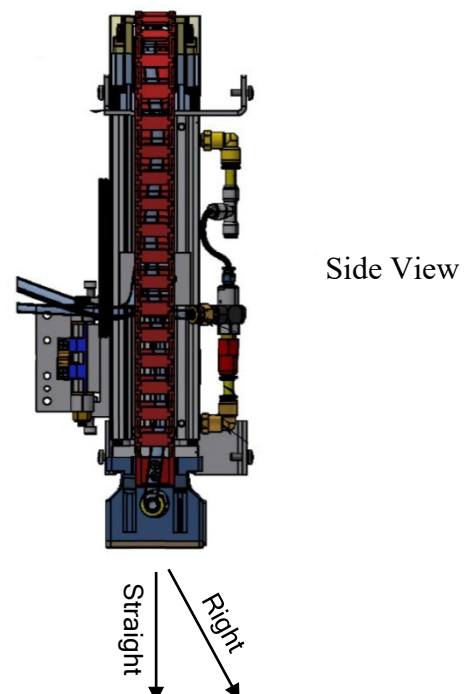
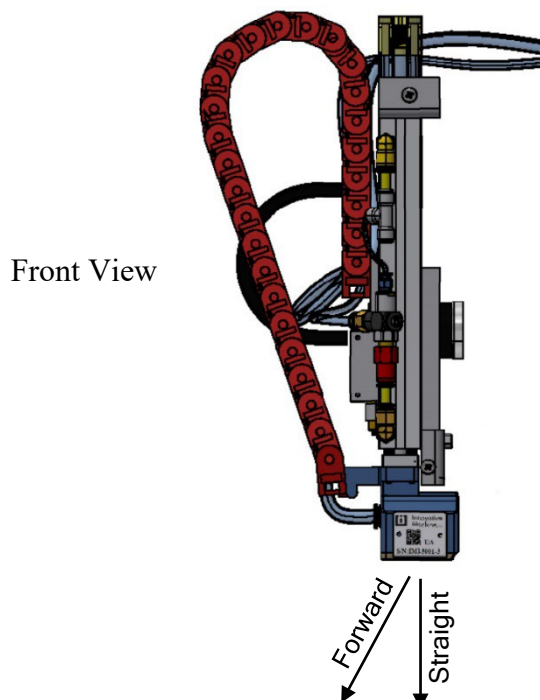

Proper Label Feed Position

Setting the Pitch and Offset for Label Position

The pitch will determine where the text is on the label. If the text is not centered on the label, the print engine may double feed labels. See below for examples of good and bad pitch position.

Bad - High

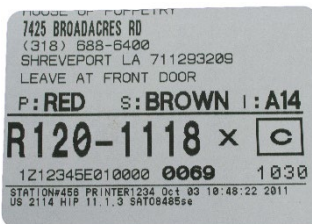

Good Pitch

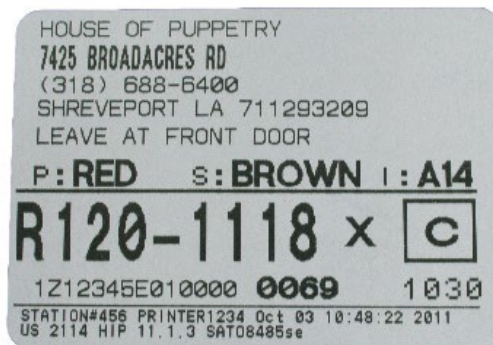

Bad - Low

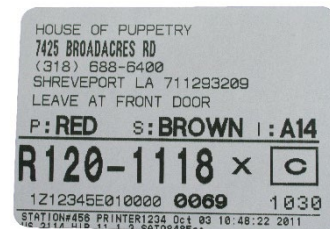

The label offset will affect how the label is printed and applied to a package. It is important to adjust the offset if there is too little or too much label queued under/over the dispense/peel bar. See below for examples of good and bad offset position. *Please note that the pictures below will not happen in normal operation as the next label is pulled back into the print engine to increase speed. You will need to watch as you feed multiple labels to see how far the next label is presented on the dispense/peel bar before it is pulled back.* For instructions on how to adjust the offset, please view the **Offset Adjustment** video or **Inconsistent Label Presentation Causing Mislabels and Misfeeds** document on the support webpage.

Bad – Too Little

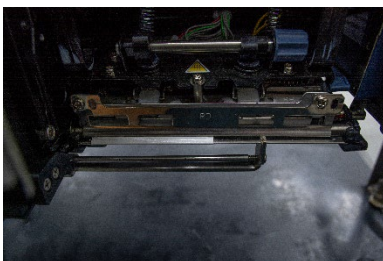

Good Offset

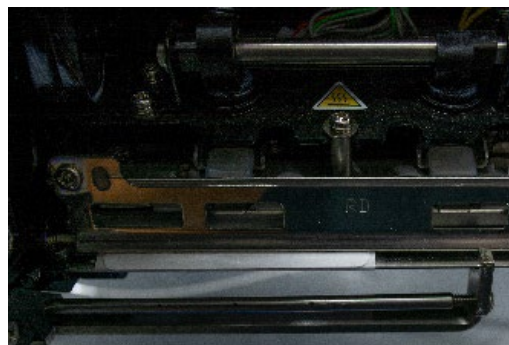

Bad – Too Much

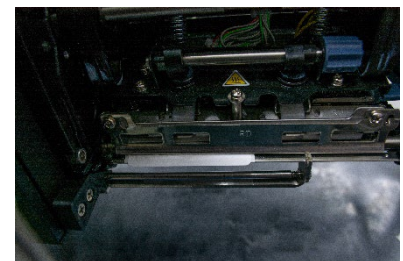

New Machine Checklist

The following checklist should be completed once a machine is installed from the manufacturer:

1. Verify all connections:
 - Power
 - Air
2. Verify the machine is properly secured to the stand.
3. Ensure all components power on properly.
 - Power switch is switched to the on position.
 - S84 print engine is powered on.
 - Initial air charge should be heard until the print engine boots.
 - Verify 80 psi on regulator.
 - Print engine LCD screen should display “ONLINE”.
 - Opening the print engine door should generate an alarm (3 beeps should be heard), and an error message should be displayed on the machine’s HMI.
 - Verify that all print engine label feed heads (tracking, print head and pressure roller) are secured.
 - Once printer engine door is closed, the LCD screen should display “OFFLINE”, and the error on the machine’s HMI will no longer be displayed.
4. Verify all idle rollers spin freely and are free of residue.
5. Properly load a roll of labels. Check that the feed path is clear of debris and residue.
 - Verify the label guide is touching the label liner. It should not distort the liner.
 - Once labels are loaded, press the “FEED” key on the print engine to present a label onto the blow head.
 - Feed 10 labels onto the blow head to ensure proper label alignment.
 - The 11th label should be square and centered on blow head.
6. Test the label blow pattern by putting the machine in maintenance mode.
 - On the print engine, press the “FEED” key to feed a label onto the blow head and blow the label onto a test box. The labels should stack on top of each other on the test box.
7. Test the machine by running a stress test of 25 packages to verify it is communicating and performing correctly.

General Maintenance

CAUTION: Before maintenance is started, ensure that both the electrical and pneumatic lockout/tagout (LOTO) has been carried out.

Proper Cleaning Supplies

- Denatured Alcohol
 - [View SDS for Denatured Alcohol](#)
- Microfiber Cloth
- Sato EZ Wipes
 - [View SDS for EZ Wipes](#)

Frequency of maintenance

- Clean the machine before and after every sort.

Cleaning (recommended daily)

- Label stock should be removed from the machine after every sort and stored in an air conditioned environment.
- Use denatured alcohol with a microfiber cloth or Sato EZ Wipes to clean the following components:
 - Rollers
 - Label guide
 - Gap sensor's black segmented rollers
 - Gap sensor window
 - Print plate/head
 - Pressure/Knurl roller assembly
 - Blow Head/Actuator Assembly

Compressed air can also be used to remove slitter dust from the machine. If you do not use denatured alcohol or EZ wipes there will be a build up of label residue on key components that will affect the application process.

Decommissioning and Disposal

When the machine has reached the end of its life cycle, care should be taken to decommission and dispose of it.

Decommissioning involves disconnecting the machine from the source and cutting all pneumatic hoses and electrical conductors. This is done to ensure that the machine is inoperable.

When disposing of the machine, it should not be treated as household waste. Disposal of any hazardous substance and/or electrical/electronic components should be in accordance with National regulations of the end user (e.g., the re-cycling of components, sub-assemblies and the equipment itself).

Troubleshooting/Support

Our [UPS Support](#) website provides documentation, videos, interactive spare parts, and FAQs to help with general maintenance and troubleshooting. If any issues are not answered after viewing the webpage, then please contact our office by calling **(386) 418-8880** or emailing support@imisolutions.com. Technicians may ask for videos or photos of the issue to be sent in to better identify the problem.

Full machines, print engines, and/or actuators may be sent to our repair department to be serviced. Please follow the instructions on the [UPS Repair Process](#) webpage to send in units.

Spare Parts

UniPrint121EB SSLAW Spare Parts List

Coupa Number	Description	Recommended Qty
7187253	UniPrint121EB SSLAW Machine (Includes Actuator Cover and Roll Feed Adaptor)	1
7187270	SKB Molded Ship Crate for UniPrint121EB SSLAW/SSHSLA Models	1
7187271	IMI Machine Cover for all UniPrint Models	1
7187286	IMI Tool Kit	1
7186057	EZ Wipes for Cleaning/Maintenance	1
7187356	Air Assist Rod for UniPrint121EB Models	1
7187357	Bearing Block Pulley (Large) for SSLAW/SSHSLA and ALA Models	1
7187368	Motor Pulley (Small) for SSLAW/SSHSLA and ALA Models	1
7187250	Take-Up Drive Belt for All UniPrint Models	1
7187310	Tracking Collar for S84 Print Engines	1
7187384	Take-Up Motor Assembly for All UniPrint Models	1
7187272	Take-Up Pin Holder for SSLAW/SSHSLA and ALA Models	1
7187316	Take-Up Spring Assembly for All UniPrint Models	1
7187374	Take-Up Sensor for All UniPrint Models	1
7187287	Spring Plungers (Pack of 2) for UniPrint121EB Actuators	1
7187378	Amplifier for UniPrint121EB Models	2
7187293	Fuse Pack (1, 2, 7.5 AMP) for UniPrint121EB Models	1
7187292	Belt/Fuse/Screw Pack for UniPrint121EB Models	1
7187394	UniPrint121EB Main PCB Board (Black)	1
7187248	Actuator Assembly for UniPrint121EB SSLAW Models	1

S84-ex Specific Parts

7187260	LH S84-ex RFID Print Engine for UniPrint121EB SSLAW (Ethernet) Models	1
7187295	Stage 1 Kit LH for S84-ex LH Print Engines	1
7187299	Stage 2 Kit LH for S84-ex LH Print Engines	1

S84NX Specific Parts

7187458	LH S84NX RFID Print Engine for UniPrint121EB SSLAW (Ethernet) Models	1
7187471	Stage 1 Kit LH for S84NX LH Print Engines	1
7187472	Stage 2 Kit LH for S84NX LH Print Engines	1

UniPrint121EB SSHSLA Spare Parts List

Coupa Number	Description	Recommended Qty
7187257	UniPrint121EB SSHSLA Machine (Includes Actuator Cover and Roll Feed Adaptor)	1
7187262	LH S84-ex RFID Print Engine for UniPrint121EB SSHSLA (Ethernet) Models	1
7187270	SKB Molded Ship Crate for UniPrint121EB SSLAW/SSHSLA Models	1
7187271	IMI Machine Cover for all UniPrint Models	1
7187286	IMI Tool Kit	1
7186057	EZ Wipes for Cleaning/Maintenance	1
7187356	Air Assist Rod for UniPrint121EB Models	1
7187357	Bearing Block Pulley (Large) for SSLAW/SSHSLA and ALA Models	1
7187368	Motor Pulley (Small) for SSLAW/SSHSLA and ALA Models	1
7187250	Take-Up Drive Belt for All UniPrint Models	1
7187310	Tracking Collar for S84ex Print Engines	1
7187384	Take-Up Motor Assembly for All UniPrint Models	1
7187272	Take-Up Pin Holder for SSLAW/SSHSLA and ALA Models	1
7187316	Take-Up Spring Assembly for All UniPrint Models	1
7187374	Take-Up Sensor for All UniPrint Models	1
7187295	Stage 1 Kit LH for S84-ex LH Print Engines	1
7187299	Stage 2 Kit LH for S84-ex LH Print Engines	1
7187287	Spring Plungers (Pack of 2) for UniPrint121EB Actuators	1
7187378	Amplifier for UniPrint121EB Models	2
7187293	Fuse Pack (1, 2, 7.5 AMP) for UniPrint121EB Models	1
7187292	Belt/Fuse/Screw Pack for UniPrint121EB Models	1
7187394	UniPrint121EB Main PCB Board (Black)	1
7187249	Actuator Assembly for UniPrint121EB SSHSLA Models	1

Support Links for All UniPrint Models

Scan the QR code with your phone/tablet or click the model

UniPrint109

[HSLA](#)



[SSLAW](#)



UniPrint116

[HSLA](#)



[SSLAW / SSHSLA](#)



UniPrint121EB

[ALA LH / RH](#)



[SSLAW / SSHSLA](#)



UK/EC DECLARATION OF CONFORMITY

**Manufacturer Business Name & Full Address**

Innoivative Machines Inc.
6115 NW 123rd place
Gainesville
FL 32653
USA

European Authorized Representative

Hold Tech Files Ltd
Dun Iseal, Newtown, Gaulsmill
Ferrybank, Waterford
X91F638
Republic of Ireland

Person Authorized to Compile the Technical File Name & Address:

Hold Tech Files Ltd Dun Iseal, Newtown, Gaulsmill, Ferrybank, Waterford, X91F638 Republic of Ireland

Machine Details

Model: Uniprint121EB SSLAW

Description: Printer and Label application

Serial #: XXXXXXXX

Electrical Information: 230 Vac Single Phase 50Hz + PE

I declare that the machinery fulfils all the relevant provisions of these UK Regulations: Supply of Machinery (Safety) Regulations 2008 as amended and the Electromagnetic Compatibility Regulations 2016 as amended, and these European Directives: Machinery Directive 2006/42/EC and Electromagnetic Compatibility Directive 2014/30/EU.

BS EN ISO/IEC Standards Used

BS EN ISO 4414:2010; BS EN ISO 11201:2010; BS EN ISO 12100:2010; BS EN ISO 13849-1:2015; BS EN ISO 13857:2019; BS EN ISO 14118:2018; BS EN ISO 14120:2015; BS EN 55011:2016+A2:2021; BS EN 60204-1:2018; BS EN 61000-4-2:2009; BS EN IEC 61000-4-3:2020 and BS EN 61000-4-4:2012

*The Technical documentation is compiled in accordance with Annex VII of the Machinery Directive.
The Technical File provides evidence of conformity of the machine with the essential requirements of the Directive.*

Place of Declaration

Innoivative Machines Inc.
6115 NW 123rd place
Gainesville
FL 32653
USA

Date of Declaration:**Person empowered to draw up Declaration**

Name: Shawn Poole

Position: Vice President

Signature: _____



Original Declaration

