

## HSLA Inspection Checklist

### Introduction

The *HSLA Inspection Checklist* will provide visual aids to ensure the installed HSLA machines include all necessary parts in order to run during a sort. If any parts are missing or damaged, they will need to be replaced or repaired as soon as possible.

A list of parts available in Coupa is provided at the end of this document. For any parts not included in the list, please email our sales department at [sales@imisolutions.com](mailto:sales@imisolutions.com) to see if it is available to be purchased.

If the HSLA machine needs to be sent in for repair, follow the instructions on the [UPS Repair Process](#) webpage.

A sample checklist is located at the end of this document to record all necessary information from the machines.

### Frame Components

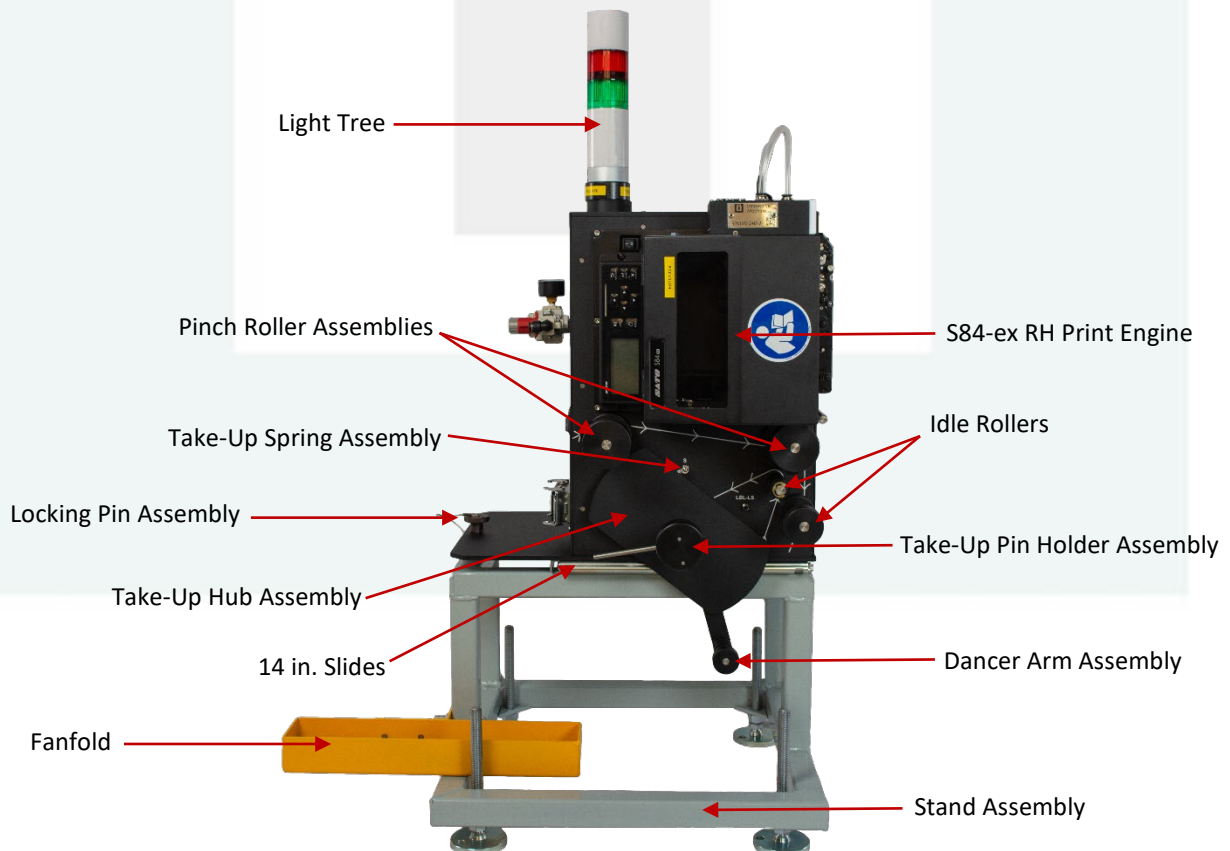

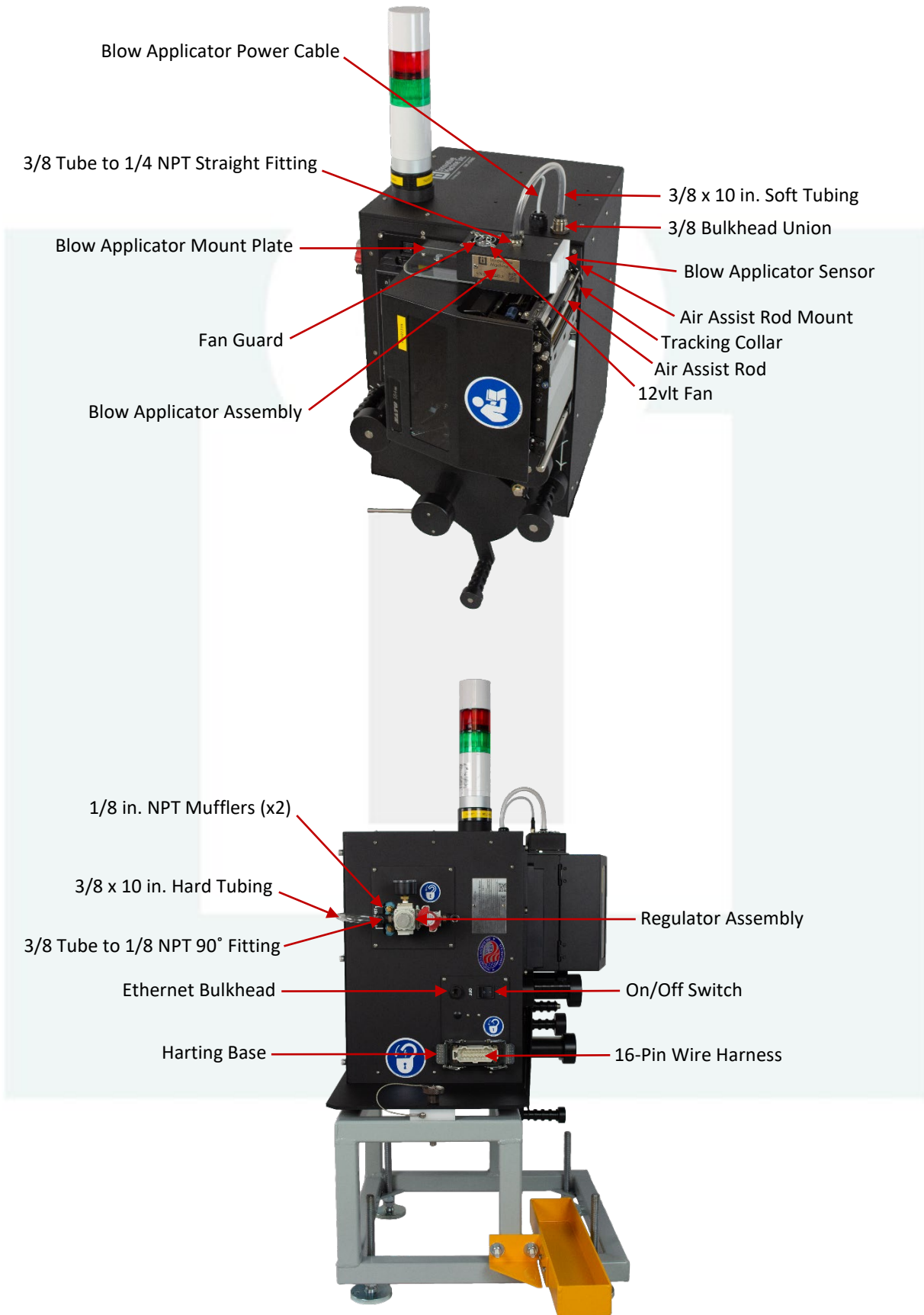

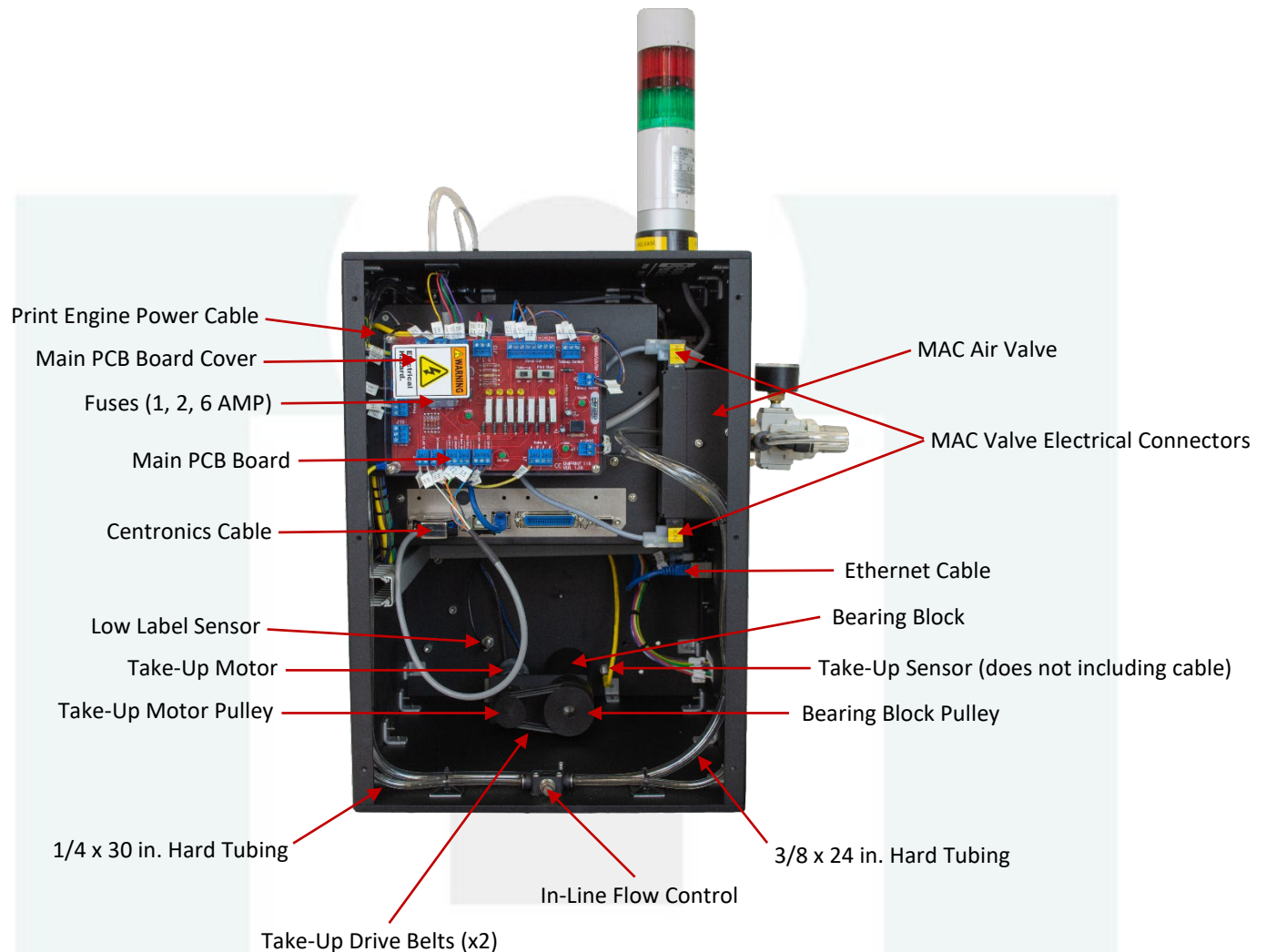

## Print Engine

All S84-ex print engines should be RFID compatible. The RFID sticker should be located on the front door of all RFID print engines. The RFID option can be viewed in the settings menu if it is enabled. If this option is not visible, and there is no RFID sticker, then an RFID kit will need to be installed by the IMI repair group. Please visit the [UPS Repair Process](#) webpage for instructions on how to send in the print engine for repair.

Stage kit rebuilds are necessary to perform at the recommended intervals in order to maintain good performance.

- Stage 1 kits include a print plate, knurl/pressure roller assembly, filter, platen roller B, and platen roller C. This stage kit should be rebuilt every 45,000 meters. When a stage 1 kit is replaced, the head counter should be cleared to accurately track the meter count on the print head and respective wear parts.



- The stage 2 kit includes a gear assembly and dispense/peel bar. This kit should be replaced every 150,000 meters or annually, whichever comes first. The meter count will need to be tracked by adding the previous head counts since the last time a stage 2 kit was replaced.



## Sample Checklist

<b>Frame #:</b>	<b>RFID:</b> yes <input type="checkbox"/> no <input type="checkbox"/>	<b>Life Count:</b> m
<b>Print Engine #:</b>	<b>Stage 1 Kit:</b> m	
<b>Blow Applicator #:</b>	<b>Stage 2 Kit:</b> m	
<b>Notes:</b>		

<b>Frame #:</b>	<b>RFID:</b> yes <input type="checkbox"/> no <input type="checkbox"/>	<b>Life Count:</b> m
<b>Print Engine #:</b>	<b>Stage 1 Kit:</b> m	
<b>Blow Applicator #:</b>	<b>Stage 2 Kit:</b> m	
<b>Notes:</b>		

<b>Frame #:</b>	<b>RFID:</b> yes <input type="checkbox"/> no <input type="checkbox"/>	<b>Life Count:</b> m
<b>Print Engine #:</b>	<b>Stage 1 Kit:</b> m	
<b>Blow Applicator #:</b>	<b>Stage 2 Kit:</b> m	
<b>Notes:</b>		

<b>Frame #:</b>	<b>RFID:</b> yes <input type="checkbox"/> no <input type="checkbox"/>	<b>Life Count:</b> m
<b>Print Engine #:</b>	<b>Stage 1 Kit:</b> m	
<b>Blow Applicator #:</b>	<b>Stage 2 Kit:</b> m	
<b>Notes:</b>		

<b>Frame #:</b>	<b>RFID:</b> yes <input type="checkbox"/> no <input type="checkbox"/>	<b>Life Count:</b> m
<b>Print Engine #:</b>	<b>Stage 1 Kit:</b> m	
<b>Blow Applicator #:</b>	<b>Stage 2 Kit:</b> m	
<b>Notes:</b>		

<b>Frame #:</b>	<b>RFID:</b> yes <input type="checkbox"/> no <input type="checkbox"/>	<b>Life Count:</b> m
<b>Print Engine #:</b>	<b>Stage 1 Kit:</b> m	
<b>Blow Applicator #:</b>	<b>Stage 2 Kit:</b> m	
<b>Notes:</b>		

## HSLA Spare Parts List

Coupa #	IMI #	Description	Price
7187264	604-0006	RH S84-ex RFID Print Engine for UniPrint116 HSLA (Ethernet) Models	5126.31
7187291	632-0001	Stage 1 Kit RH for S84-ex RH Print Engines	582.43
7121254	R29219000	Sato Part, 203DPI Print Plate for all S84ex Print Engines	302.82
7121256	R29177000	Sato Part, Platen Roller C for all S84ex Print Engines	77.87
7121257	R29176000	Sato Part, Platen Roller B for all S84 Print Engines	64.89
7184678	R27602000	Sato Part, Pressure (Knurl) Roller Assembly for S84ex RH Print Engine	135.47
7121258	P18026010	Sato Part, Filter Pad on back of Print Engine for all S84 Print Engines	1.93
7187298	632-0005	Stage 2 Kit RH for S84-ex RH Print Engines	323.75
7186055	R21138001	Sato Part, Gear Assembly for S84ex RH Print Engine	230.78
7184679	P17053000	Sato Part, Dispense Bar for all S84 Print Engines	92.95
7187304	633-0001	Label Path Sticker for UniPrint116 HSLA Models	3.00
7187290	631-0002	Fuse Pack (1, 2, 6 AMP) for UniPrint109 and 116 Models	5.67
7187289	631-0001	Belt/Fuse Pack - (2) Belts and (3) Fuse Packs for UniPrint109 and 116 Models	30.41
7187275	621-0002	Pair or 14" Slides for HSLA Stand	129.32
7187274	621-0001	Locking Pin Assembly for HSLA Stand	46.35
7187273	621-0000	UniPrint HSLA Machine Stand (Includes Fanfold and Locking Pin)	1076.81
7187244	601-3000-1	S84 Blow Applicator for HSLA Models	1326.13
7187243	522-0010	Centronics Cable for UniPrint109 and 116 Models	79.31
7187242	522-0009	MAC Valve Electrical Connectors (1 Pair) for UniPrint109 and 116 Models	80.34
7187241	522-0008	Blow Applicator Power Cable for UniPrint109 and 116 HSLA Models	48.15
7187400	522-0006	Low Label Sensor for all UniPrint Models	142.14
7187398	522-0004	Print Engine Power Cable for S84-ex RH Print Engines	20.39
7187393	521-0002	UniPrint116 Main PCB Board (Red)	746.75
7187389	520-0011	Light Tree for UniPrint109 and 116 HSLA Models	280.16
7187384	520-0005	Take-Up Motor Assembly for all UniPrint Models	117.68
7187377	513-0002	Fan Guard for UniPrint109 and 116 Blow Applicators	7.47
7187376	513-0001	12V Fan for UniPrint109 and 116 Blow Applicators	41.82
7187375	512-0002	Blow Applicator Sensor for UniPrint109 and 116 Blow Applicators	248.90
7187374	512-0001	Take-Up Sensor for all UniPrint Models (Does Not Include Cable)	120.51
7187373	509-0002	Ethernet Bulkhead	17.59
7187372	509-0001	Harting Base Connector for all UniPrint Models	66.95
7187371	507-0002	Ethernet Cable for SSHSLA, HSLA, and ALA Models	6.18
7187370	507-0001	3-Pin Male Receptacle for UniPrint109 and 116 Blow Applicators	35.02
7187366	504-0001	On/Off Power Switch for all UniPrint Models	9.77



7187359	246-0004	Air Regulator for UniPrint116 HSLA Models	136.84
7187355	246-0001	Air Assist Rod for UniPrint109 and 116 Models	43.26
7187352	244-0004	1/4" OD X 30" Length Hard Tubing	5.82
7187351	244-0003	3/8" OD X 24" Length Hard Tubing	14.07
7187350	244-0002	3/8" OD X 10" Length Hard Tubing	12.51
7187349	244-0001	3/8" OD X 10" Length Soft Tubing	5.15
7187347	243-0002	MAC Air Valve for UniPrint109 and 116 Models	191.67
7187344	242-0001	1/4" Tube In-Line Flow Control	18.89
7187343	241-0012	3/8" Tube Bulkhead Union	9.79
7187341	241-0010	1/8" NPT Muffler	6.59
7187337	241-0005	3/8" Tube to 1/8" NPT QC 90 Degree Fitting	6.18
7187334	241-0003	3/8" Tube to 1/4" NPT QC Straight Fitting	6.37
7187333	241-0002	3/8" Tube to 1/8" NPT QC Straight Fitting	6.18
7187332	241-0001	1/4" Tube to 1/8" NPT QC Straight Fitting	5.82
7187331	150-0004	Blow Applicator Nozzles (Pack of 10) for UniPrint109 and 116 Models	10.61
7187330	150-0003-1	Blow Applicator Mounting Bolt Assembly for UniPrint109 and 116 Models	3.00
7187329	150-0002	Blow Applicator Set Screw for UniPrint109 and 116 Models (Pack of 10)	5.20
7187328	150-0001	Air Assist Mount Set Screw (Pack of 10)	5.20
7187327	130-0021	Air Assist Rod Mount for all UniPrint Models	71.59
7187322	130-0017	RFID Tuning Insert for RH S84-ex Print Engines	68.00
7187321	130-0016	Main PCB Board Cover for all UniPrint Models	39.29
7187320	130-0015	Blow Applicator Mount Plate for UniPrint109 and 116 HSLA Models	43.26
7187318	130-0013	Bearing Block Assembly for All UniPrint Models	357.93
7187317	130-0012	Pinch Roller Assembly for all UniPrint Models	110.93
7187316	130-0011	Take-Up Sprint Assembly for all UniPrint Models	6.77
7187315	130-0010	Dancer Arm Assembly for HSLA Models	175.65
7187312	130-0008	Take-Up Hub Assembly for HSLA Models	143.34
7187310	130-0006	Tracking Collar for S84-ex Print Engines	26.78
7187283	130-0003	Fanfold Mount Assembly for HSLA Models	153.26
7187261	130-0001	Take-Up Pin Holder for HSLA Models	115.36
7187250	126-0001	Take-Up Drive Belt for all UniPrint Models	6.70
7187390	121-0020	Take-Up Shaft Spacer for all UniPrint Models	9.02
7187379	121-0019	Dancer Arm Bearing (Plastic) for all UniPrint Models	12.04
7187346	121-0016	Dual Motor Pulley (Small) for HSLA Models	31.93
7187335	121-0015	Dual Bearing Block Pulley (Large) for HSLA Models	47.38
7187238	107-0001	Cam for S84-ex Print Engines	91.67