



OPERATION MANUAL

UniPrint121EB SSHSLA 2.0 Operator Manual

(Original Instructions)

Innovative Machine, Inc.

imisolutions.com

Copyrights

Any unauthorized reproduction of the contents of this document, in part or whole, is strictly prohibited.

Limitation of Liability

Innovative Machine, Inc. (IMI) makes no representations or warranties of any kind regarding this material, including, but not limited to, implied warranties of merchantability and fitness for a particular purpose. IMI shall not be held responsible for errors contained herein or any omissions from this material or for any damages, whether direct, indirect, incidental, or consequential, in connection with the furnishing, distribution, performance or use of this material. Specifications and contents in this document are subject to change without notice.

Document Name	UNIPRINT121EB SSHSLA 2.0 Operator Manual
Language	English (Original Instructions)
Revision	2 – 11/2024



6115 NW 123rd Place
Gainesville, FL 32653
(386) 418-8880

Table of Contents

Introduction.....	3
Identifying 1.0 vs. 2.0.....	4
Specifications	6
Important Safeguards	7
Residual Risk.....	7
Precautions for Handling, Installation, and Use.....	8
Foreseeable Misuse	9
Noise.....	9
Limitations of Use.....	9
Lifting and Handling	10
Definition of Components.....	11
Component Overview	11
Print Engine Detail	12
Identification Tag	13
Component Detail	14
Roll Feed	14
Label Guide.....	15
Gap Sensor	16
Print Head Pressure Switch.....	17
Extend Blow Head	18
Dancer Arm.....	19
Take Up Spool.....	20
Installation and Start-Up.....	21
Installation and Commissioning.....	21
Start-up Steps	22
Label Alignment.....	25

Proper Label Feed Position	26
Troubleshooting using the HMI	27
Home Screen Default.....	27
Maintenance Access Menus	28
Bypass Function Screen.....	29
I/O Screen	31
New Machine Checklist	32
General Maintenance	33
Frequency of maintenance	33
Cleaning includes (recommended daily).....	33
Decommissioning and Disposal.....	34
Troubleshooting/Support	35
Spare Parts	36
UniPrint121EB SSHSLA Spare Parts List.....	36
Support Links for All UniPrint Models	37
121EB SSHSLA 2.0 Wiring Diagram	38
Declaration of Conformity Example.....	39

Introduction

General use of the UniPrint121EB SSHSLA model are to apply a paper label that is 63.5mm (2.5”) wide x 44.45mm (1.75”) long, with a 47.5mm (1.870”) pitch and 66.68mm (2.625”) liner width. Tolerances on the label are .25mm (.009”). Nominal label thickness is .1mm (.004”) with the liner of .05mm (.002”) for an overall thickness of .15mm (.006”).

The UniPrint121EB SSHSLA will apply a label to the top of a package from 25.4mm (1”) to 393mm (10”) away. Package sizes will be a minimum of 50.8mm (2”) wide with a max height of 393mm (10”).

All UniPrint121EB SSHSLA model will be able to provide the following:

- Report conditions (like machine error, offline, home position, low label, etc.) through Input/Output (I/O) to the customer control panel.
- I/O devices are powered from the contained Sato Engine’s 24VDC supply.
- All sensors must be the PNP type.
- Allow for label stock replenishment in approximately 60 seconds.
- Label placement accuracy can be less than or equal to +/- 6.35mm at a max distance of 50.8mm (2”) from the centerline on the blow head.
- RFID label enabled.
- A status indicator “light tree” is located on the machine. The indicator contains an audible alarm and a multicolor light. This is controlled by the SSHSLA itself as well as the customer control panel.
- Apply labels at a rate up to 355mm/sec or 4112 labels per hour per machine.

Identifying 1.0 vs. 2.0

Use the HMI to determine which version.



1.0



2.0

The UniPrint121EB SSHSLA is a top apply machine. This means that the machine applies a label to the top of a package. As the package advances under the machine, the actuator will extend, if needed, to apply the printed label using compressed air.

This manual will display the SSHSLA in the visual aids.

121EB SSHSLA









Specifications

UniPrint121EB SSHSLA	
Dimensions and Weight	
Width	27.812" (706.42 mm)
Height	19.5" (495.3mm)
Depth	21" (533.4mm)
Weight	34.93kg (77lb)
Power Supply	
Input Voltage	AC 100 V - 240 V \pm 10% DC 24v Both supplied through Harting Connector
Frequency	AC – 50-60 Hz
Power Consumption	AC – 7.5 amps DC – 2 amps
Pneumatics	
Min/Max Pressure	5.17bar(75psi)/5.51bar(80psi)
Min Volume	11.72m ³ /h (6.0cfm)
Environmental Conditions (Without Media)	
Operating Temperature	23 to 104 °F (-5 to 40 °C)
Storage Temperature	-4 to 140 °F (20 to 60 °C)
Operating Humidity	15 to 85% RH (Non-condensing)
Storage Humidity	15 to 90% RH (Non-condensing)

Important Safeguards

Residual Risk

CE versions of the UniPrint121EB SSHSLA use a variety of pictographic symbols. These symbols show the safe and correct operation of the machine and how to prevent injury to others and property damage. The symbol explanations are as follows:

	<p>Electrical Shock / Electrical Hazard</p>
	<p>Lock Out / Electrical Power. Before any maintenance of the machine is to be done, the Electrical Lock-Out Tag-Out should be used.</p>
	<p>Lock Out / Pneumatic. Before any maintenance of the machine is to be done, the Pneumatic Lock-Out Tag-Out should be used.</p>
	<p>Hand Entanglement / Belt Drive Hazard</p>
	<p>Please read and understand all manuals prior to use.</p>
	<p>This machine is UKCA and CE Certified in accordance with the applicable UK & EU Directives and BS EN Standards, current at the time of certification; any modification to this machine, without the prior consent of the manufacturer, may invalidate the compliance of the machine.</p>

Precautions for Handling, Installation, and Use

This section describes how to safely operate the UniPrint121EB SSHSLA machine. Be sure to read and understand all instructions carefully before you install and/or use the machine.

- Place the machine on the stand provided.
- Do not place objects on the machine.
- Do not place containers filled with liquid on the machine. If any liquid spills onto or into the machine, immediately power off and disconnect power. If you operate the machine under these conditions, it could cause a fire, electric shock or malfunction.
- Do not place objects inside the machine. If a foreign object gets inside the machine, immediately power off and disconnect the power.
- Use only specified voltages. Using voltages outside specified ranges could cause a fire, electric shock or malfunction.
- Always connect the machine to electrical ground. Not using the grounding wire could cause electric shock.
- Do not share the machines power source with other electrical devices, doing so could cause power fluctuations and performance issues.
- Do not break, change, overly bend, twist, place heavy objects on or pull the 16 pin harging interface cable. If the cable becomes damaged, contact Innovative Machine Inc. or the Technical Support Center. Using the cable in this condition could cause a fire, electric shock or malfunction.
- If the machine has been dropped or broken, immediately power off and disconnect the power. Using a damaged machine could cause a fire, electric shock or malfunction.
- Do not use the machine if anything is unusual about it, i.e., smoke, unusual smells, or broken parts. Continuing to use the machine in this state, could cause a fire, electric shock or malfunction.
- Do not disassemble or modify the machine. Doing so could cause a fire, electric shock or malfunction.
- Do not place the machine in a location subject to water and/or oil. Water and/or oil entering the machine may cause a fire, electric shock, or malfunction.

Foreseeable Misuse

To prevent damage to the machine and protect the customer from harm:

- Do not climb on the machine for any reason. It is not designed for this purpose. Safe means of access have been provided by either the Manufacturer and/or the End User.
- Do not operate the machine unless trained and authorized to do so. “Read Manual before operating” decals are affixed at Control Stations.
- Do not use the machine outdoors. It is rated for indoor use only.
- Do not operate in an explosive atmosphere, i.e., ATEX environment. It is not rated for this purpose.

Noise

The maximum corrected noise levels recorded for this machine was 78.3 db(A) and 81.3 db(C). There is no requirement for hearing protection to be worn in the vicinity of this machine, unless required as an End User site policy.

Limitations of Use

The UniPrint121EB SSHSLA should always be inside for operation and storage. The machine should only be operational when temperatures are between -5 to 40 °C (23 to 104 °F) and stored in temperatures between -20 to 60 °C (-4 to 140 °F). The machine should be in an environment where the humidity is between 15 to 85% RH (Non-condensing).

Only trained personnel should operate and conduct maintenance on the UniPrint121EB SSHSLA machine. All personnel should read and comprehend the operation manual in its entirety before operating or conducting any maintenance on the machine.

Lifting and Handling

The UniPrint121EB SSHSLA machines exceed the weight recommended for one person to move or handle (SSHSLA = 34.93kg). Two people are required when handling the machine at all times. Handling involves installation, removal or replacment for service.

The UniPrint family of label machines must be handled correctly to not damage certain components.

- **DO NOT** use the Light Tree (A), Regulator (B), Actuator (C), or Dancer Arm (D) when moving or positioning the equipment.
- The machine **MUST** be picked up with a person on each side of the frame while using the designated handles (E).
- UniPrint121EB SSHSLA are not mounted from the factory to the stand. The stand is shipped and mounted separately.
- The UniPrint121EB SSHSLA is mounted to the stand with (2) Y Mounts and (6) 1/4-20 nuts to secure it in place.

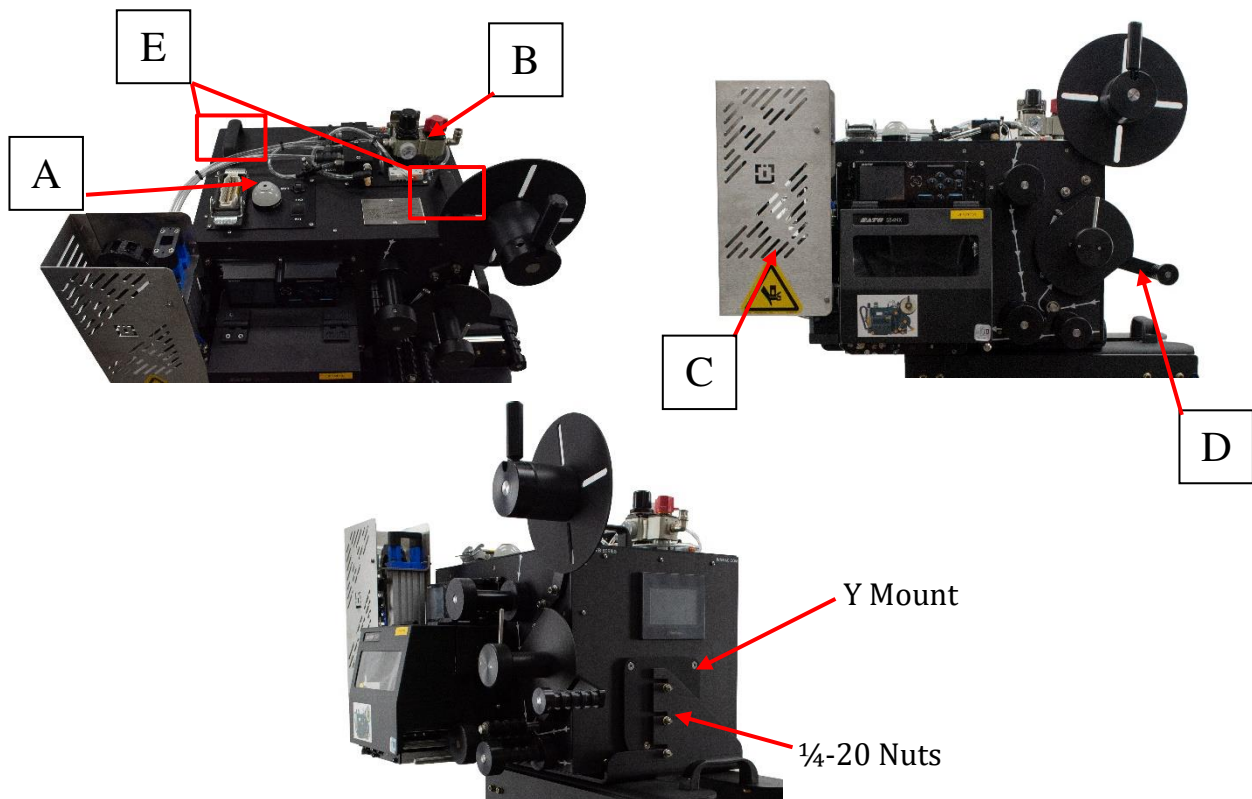

Definition of Components

Component Overview

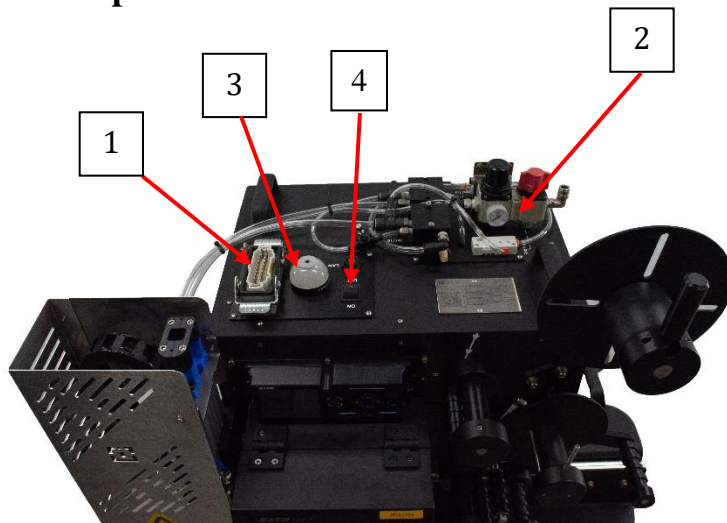

1	Harting Connector
2	Regulator/Disconnect
3	Light Tree
4	Power Switch
5	SATO LCD Display
6	SATO S84-EX OR S84NX Print Engine
7	Actuator Assembly
8	Blow Head
9	Roll Feed
10	Take Up Hub
11	Dancer Arm
12	Idle Roller
13	Pinch Rollers

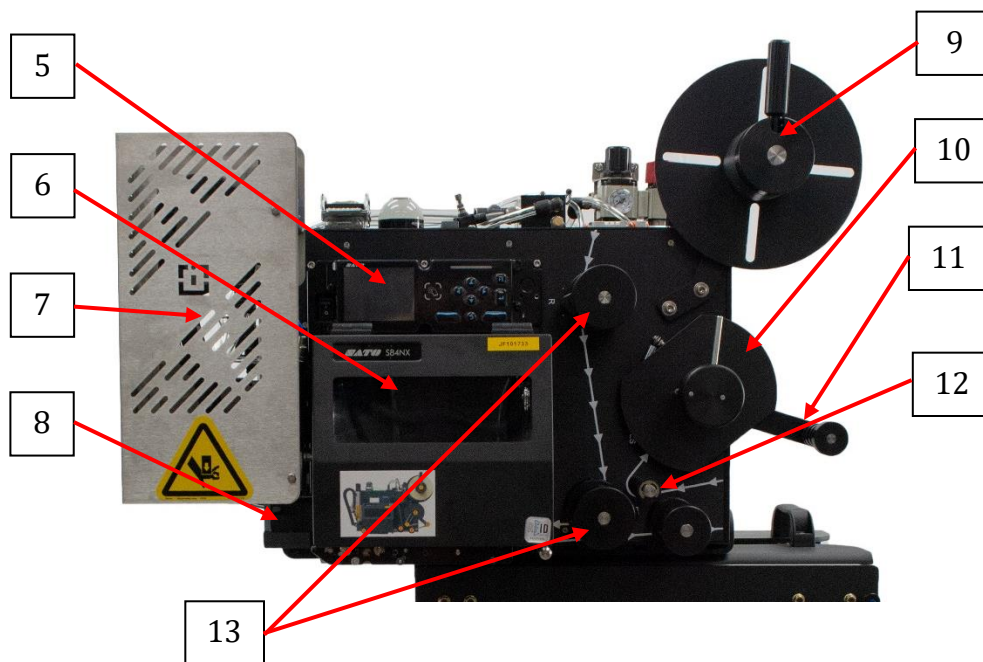

Print Engine Detail

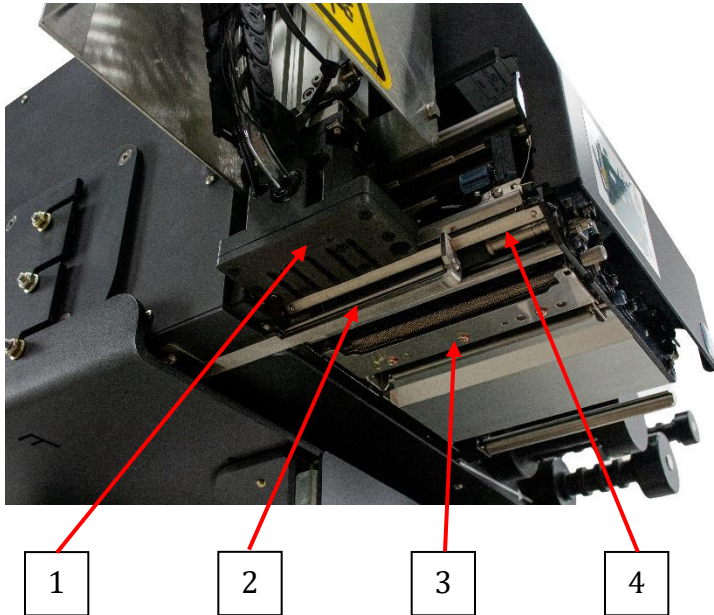

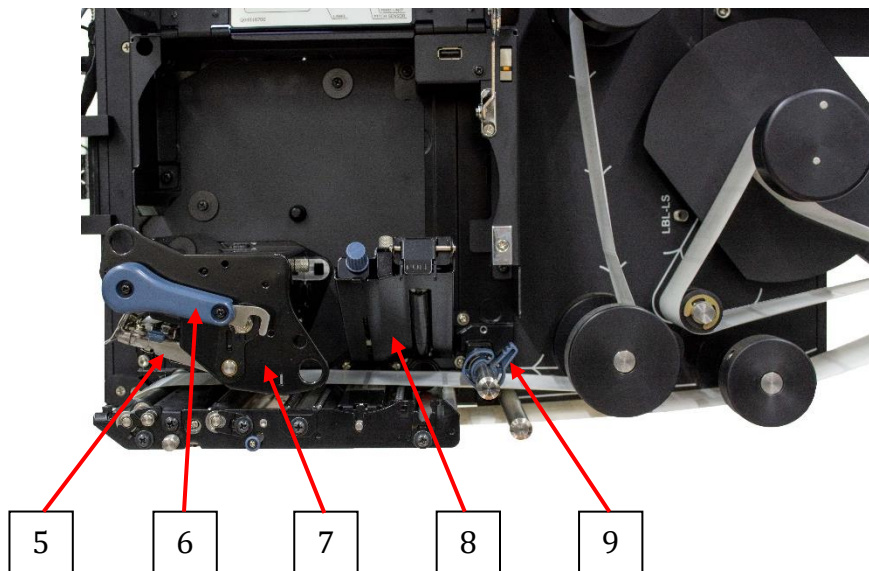

1	Blow Head
2	Air Assist Rod
3	Pressure/Knurl Roller Assembly
4	Dispense/Peel Bar
5	Print Plate/Head
6	Latch for Print Plate/Head
7	RFID Insert
8	Gap Sensor
9	Label Guide





Identification Tag

All identification tags will list the model type, frame serial number, machine info, Innovative Machine contact information, and a QR code to access the 121EB SSHSLA support webpage. This webpage includes helpful documents, videos for routine maintenance, interactive images to reference replacement parts, and more.

Non-CE Version

 Innovative Machine, Inc. +01 386-418-8880 sales@imisolutions.com		6115 NW 123rd Place Gainesville, FL 32653 USA	
Scan for Support 	Model: Uniprint121EB SSHSLA		
	Serial Number : IMI - 1040 - 18		
	Power Supply: 110/240 Vac, Single Phase 50/60Hz + PE		
	Weight/Mass: 74 lbs. / 33.6 Kgs		
	Full Working Load: 6 Amp		
	SCCR: 5KA		
	Electrical Drawing #: 091416-914 through 091416-1448		
Year of Manufacture: 2022			

CE Version

Manufacturer Info:  Innovative Machine, Inc. +01 386-418-8880 sales@imisolutions.com				6115 NW 123rd Place Gainesville, FL 32653 USA	
Scan for Support 	Machine Type: Printer and Label Application				
	Model: Uniprint121EB SSHSLA				
	Serial Number: IMI - 1004 - 18				
	Power Supply: 120/230 VAC, Single Phase, 50/60 Hz + PE				
	Full Working Load: 7.5 Amp				
	Electrical Drawing #: 090822-002 to 030				
	SCCR: 5 Kv/A				
Weight: 37 Kg / 82 lbs					
Year of Manufacture: 2022					
European Authorized Representative: Hold Tech Files Ltd., Dan Isaal, Newtown Gausmill, Ferrybank, Waterford, X91F635 Republic of Ireland					

Component Detail

Roll Feed

The roll feed allows the labels to be properly mounted/fed through the machine and maintains proper tension on the label feed. If excess or lack of tension occurs, labels can jam or feed improperly causing label application problems. To load the roll stock, lift up and down on the roll feed handle.

The low label sensor is an I/O connection to UPS's control PLC. This sensor will detect when the roll stock is low.

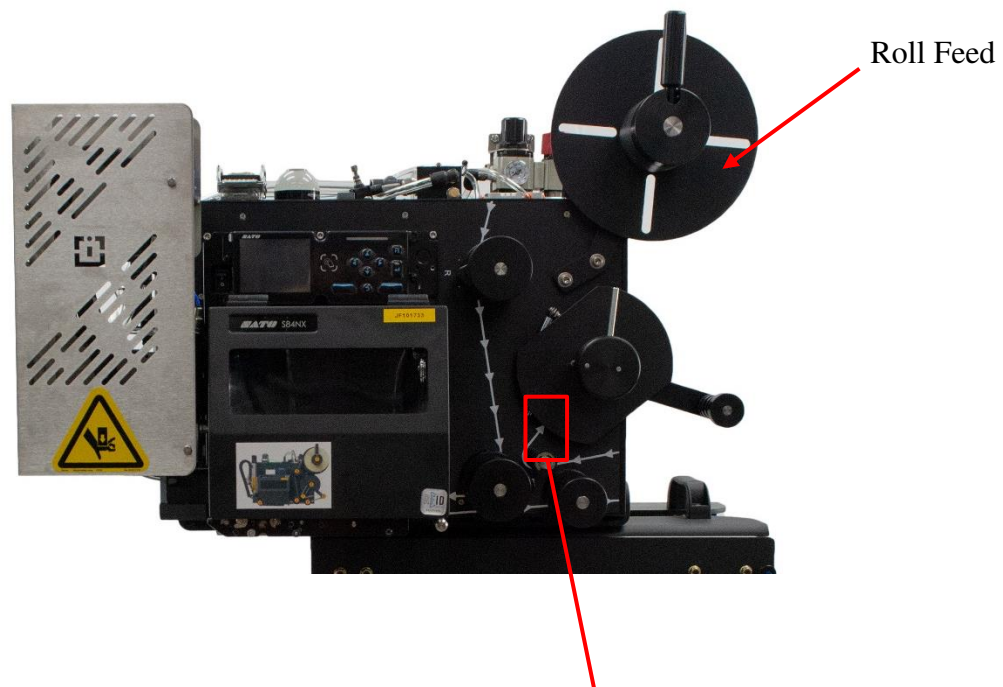

Low Label Sensor
is behind the Take
Up Back Plate

Label Guide

The label guide is a blue tab inside the S84 print engine that prevents the label liner from moving off track of the normal label feed path. If the guide is not touching the label liner, labels can get off track and result in labels bouncing. Verify the label guide is free of residue to prevent label application problems.

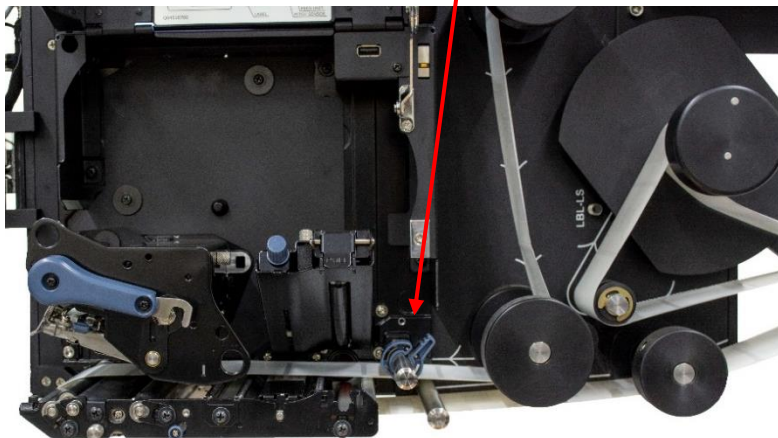
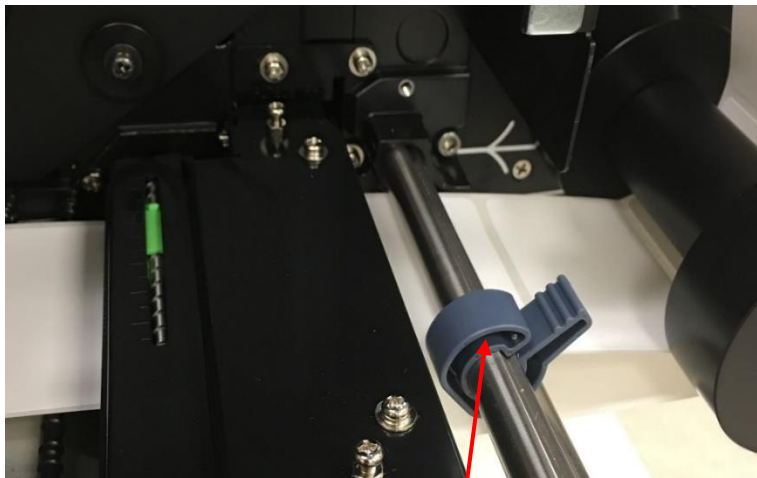

Gap Sensor

The gap sensor provides the S84 print engine with feedback on the status of labels being fed through the printer. As the labels travel through the engine, this sensor detects the labels and the gaps between the labels to ensure the availability of material to print. When the sensor is dirty it can no longer properly detect the labels and will cause a “Labels Out” fault and/or multiple blank labels to be fed at once. To correct this issue, clean the gap sensor and rollers.

If cleaning the gap sensor does not help, then you may have to calibrate the gap and I-mark sensors.

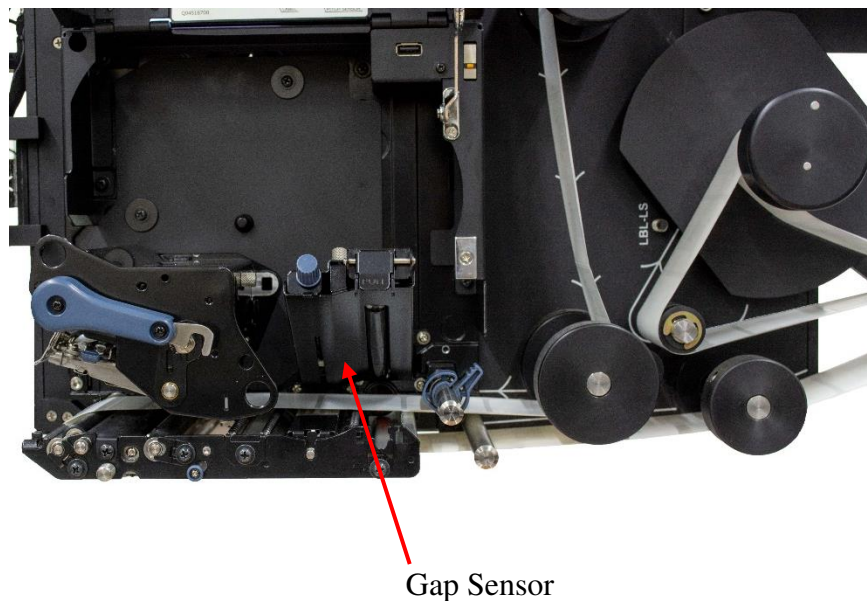

Gap Sensor

Print Head Pressure Switch

The pressure switch provides the ability to increase the pressure the print head applies to the label stock. This affects the ability of the print plate to properly contact the label for proper printing. The label stock UPS utilizes requires the least amount of pressure due to its thickness (4 mils). If the switch is increased to anything other than 1, an increase in the tension on the labels could occur causing label feed issues.

Having the pressure switch set at 2 or 3 will cause premature wear on the print head and shortens the life of this component.

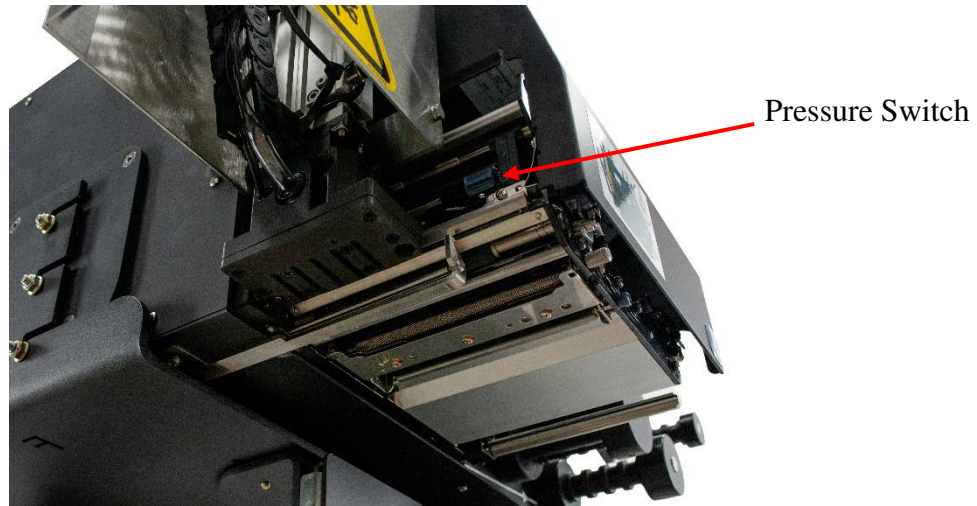

Extend Blow Head

The air hose should be secured in the 90° push-in fitting. Gently pull on the hose to verify it is secure.

The label detect photo eye detects when a label is on the blow head. This photo eye is connected to one of the amplifiers. Its value should always be set to 100. If this photo eye becomes dirty, the SSHSLA system will experience either false “Label on Blow Head” faults or will not blow the label onto the package. Cleaning the photo eye typically solves both issues.

The package detect photo eye detects how close a package is to the blow head. This photo eye is connected to the other amplifier. Its value varies from machine to machine but should be set in the range of 1500 to 1700 based on distance to package preset from the factory.

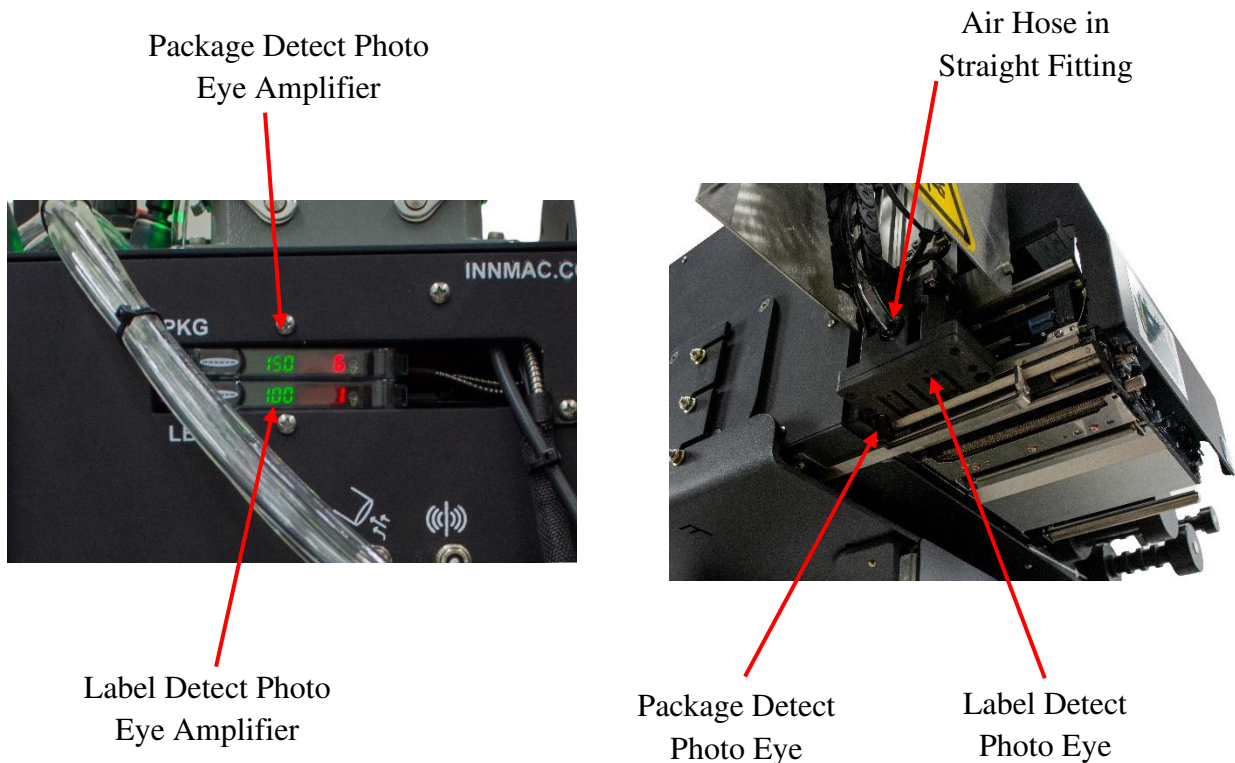

Dancer Arm

The dancer arm provides constant tension on the label liner to prevent a jam in the label feed path. The dancer arm controls when the take up spool rotates to take up any slack in the label liner. The dancer arm should move/spin freely. The photo eye inside the machine frame detects the presence of the dancer arm as it moves across. As the dancer arm travels towards the furthest point the photo eye engages the take-up spool. Once the dancer arm returns to its neutral position the photo eye dis-engages the take-up motor. If the photo eye fails, the take-up spool drive will not run. Also, if the S84 print engine door is open, the take up will turn off.

To test the photo eye, remove the liner from the take up spool and manually move the dancer arm. Verify the LED on the photo eye is changing states from amber to black. If not, then the photo eye needs to be replaced.

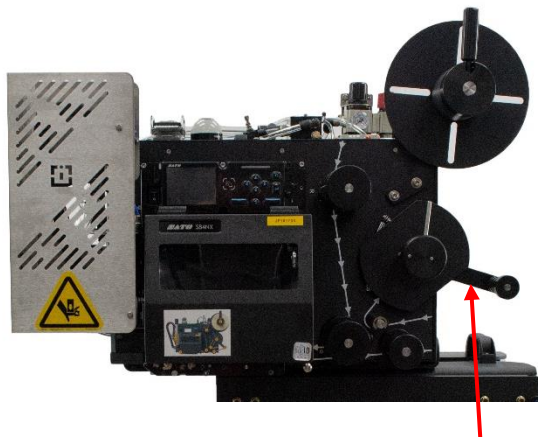

Dancer Arm

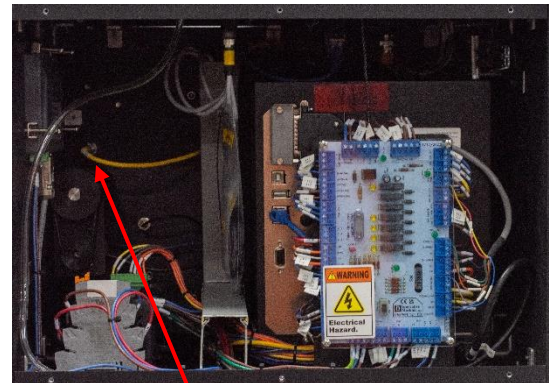

Photoeye

Take Up Spool

The take up spool provides the machine with a simple way to retrieve and store all used label liner and keep proper tension on the feed system. The motor for the take up spool is controlled by the dancer arm and should only be engaged while the dancer arm is extended past its resting position. If the driving belt is worn or the motor fails, the take up spool will not respond to the dancer arm.

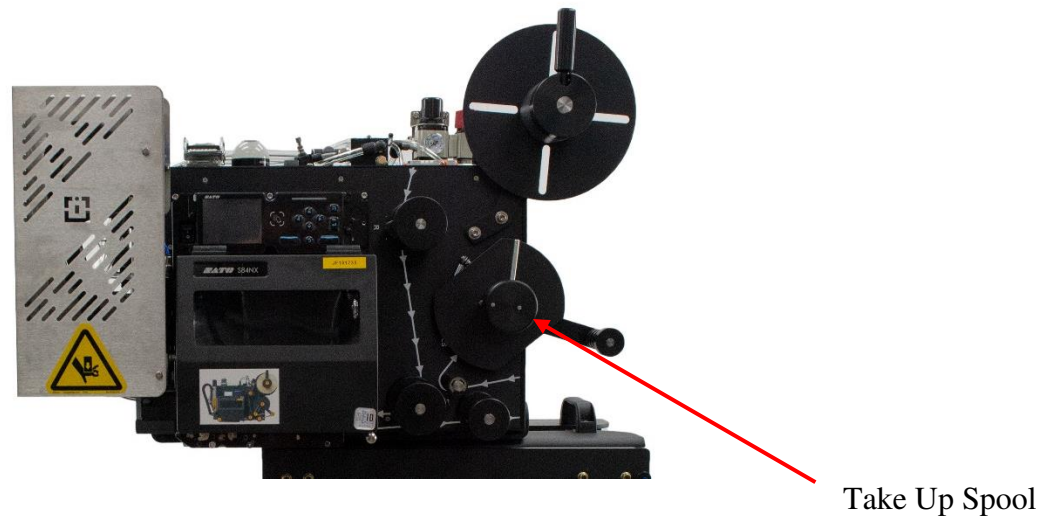

Installation and Start-Up

Installation and Commissioning

Once installed onto the stand, the 16-pin harting connector can be plugged in and secured to the harting base. The input voltage will be supplied through the harting connector as 100 – 240V \pm 10%, 50-60Hz AC and 24v DC. The power consumption of AC is 7.5 amps while DC usage is 2 amps.

The minimum pneumatic supply should be 5.17bar (75 psi) and maximum pneumatic supply should be 5.51bar (80psi). The minimum pneumatic volume is 11.72 m³/h (6.0 cfm).

Start-up Steps

1. Make sure the Harting, Air In and LAN connections are attached.
2. Make sure the air disconnect is open (label should display SUP and regulator will show pressure).
3. Make sure the regulator is reading 80psi. If not, adjust accordingly.

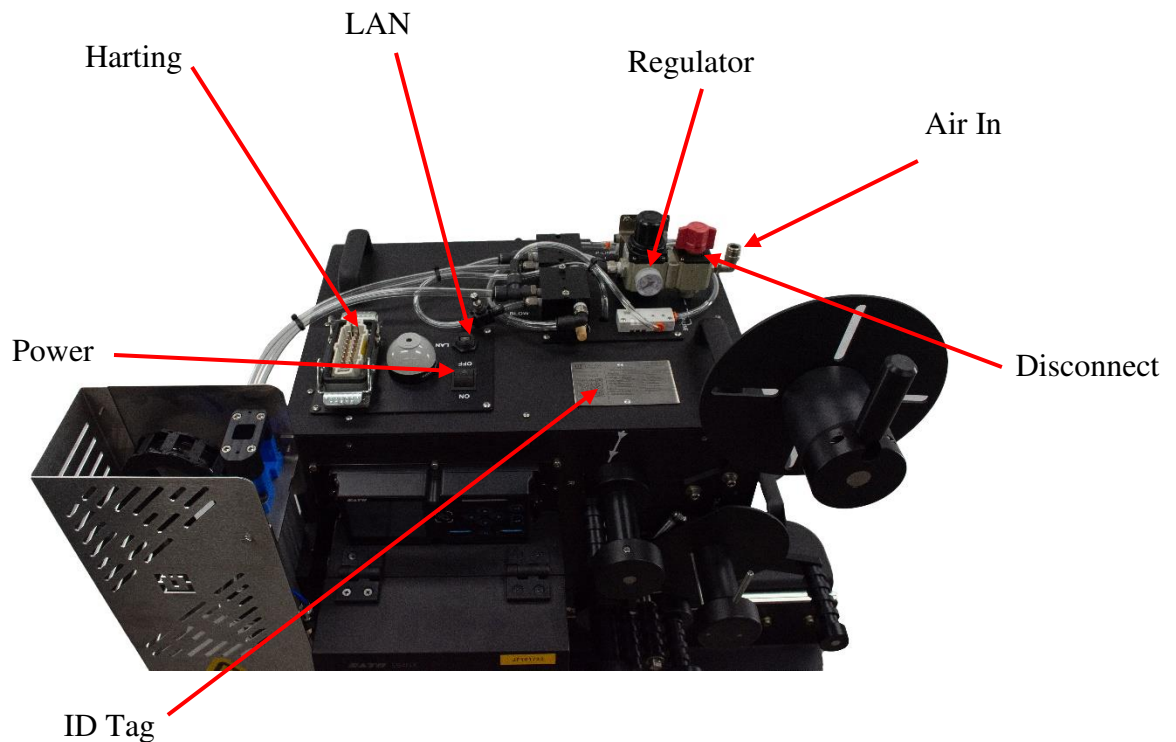

4. Load the labels, following the path printed on the main plate and represented in the pictures on the front of the machine, making sure not to miss any pinch or standard rollers.

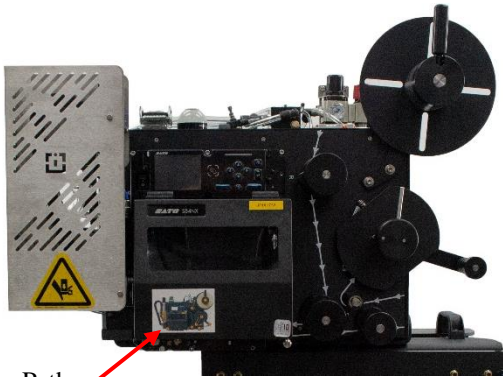

Follow Path
Shown on
Sticker

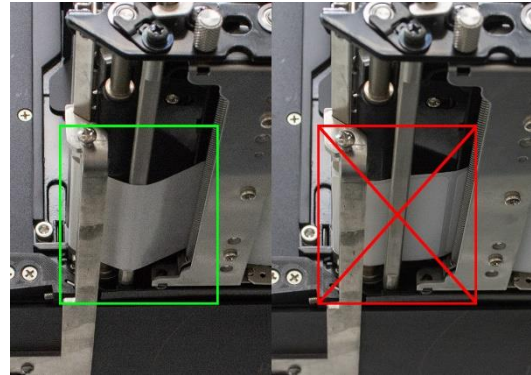

5. Using the power switch, turn on the machine. If the Sato print engine is not powered up, use its power switch to turn it on.
6. When powered up, the HMI should display this screen. In this mode the actuator is disabled by default.

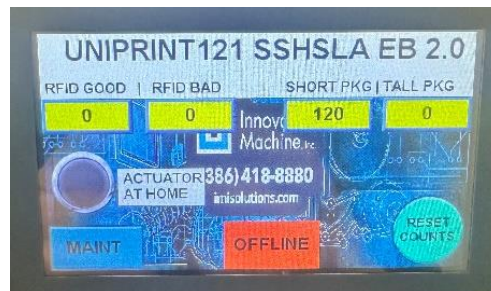

7. Press the “OFFLINE” button. The actuator will withdraw a slight amount (~ 1/2”) and the HMI will display:

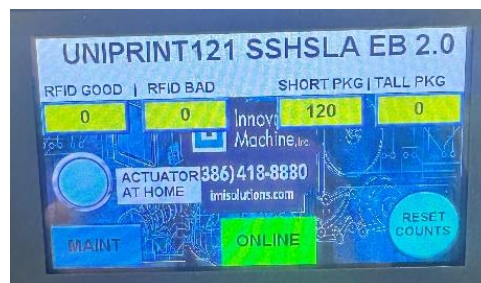

- Continue with this step if this process is being performed after a power on.

Feed a few labels to make sure they are registering correctly on the blow head.

S84ex

- Press the “LINE” key on the S84ex print engine. “OFFLINE” should be shown on the display.
- On the UPS Control Panel HMI, turn the maintenance/pre-trip.
- Place your hand or a package in front of the blow head, press the “FEED” key on the print engine.
- If multiple labels dispense, remove them from the blow head.
- Press the “FEED” key. Each time the “Feed” key is pressed a label should be dispensed on the blow head and blown onto your hand or package.
- Make sure to run at least five labels without any problems.
- Press the “LINE” key on the print engine. “ONLINE” should be shown on the display.
- Turn the maintenance/pre-trip off.



S84NX

- Press the left rectangular button. “Offline” should be shown on the display.
- On the UPS Control Panel HMI, turn the maintenance/pre-trip.
- Place your hand or a package under the blow head and press the right rectangular button.
- If multiple labels dispense, remove them from the blow head.
- Press the right rectangular button. Each time the button is pressed a label should be dispensed on the blow head and blown onto your hand or package.
- Make sure to run at least five labels without any problems.
- Press the left rectangular button. “Online” should be shown on the display.
- Turn the maintenance/pre-trip off.



Label Alignment

Adjustments to label tracking is only needed when the label is consistently being fed onto to blow head at an angle.

Once an adjustment to the tracking has been made, the label should be centered on the blow head face plate and in alignment with the label detect photo eye. For example, the label below is perfectly aligned with the red line.



The label should always apply straight down from the center of the blow head. The actuator arm can be adjusted three different ways: up/down, outwards, and left (with shim). The adjustment is dependent on the way the label is fed onto the blow head and applied to a package.

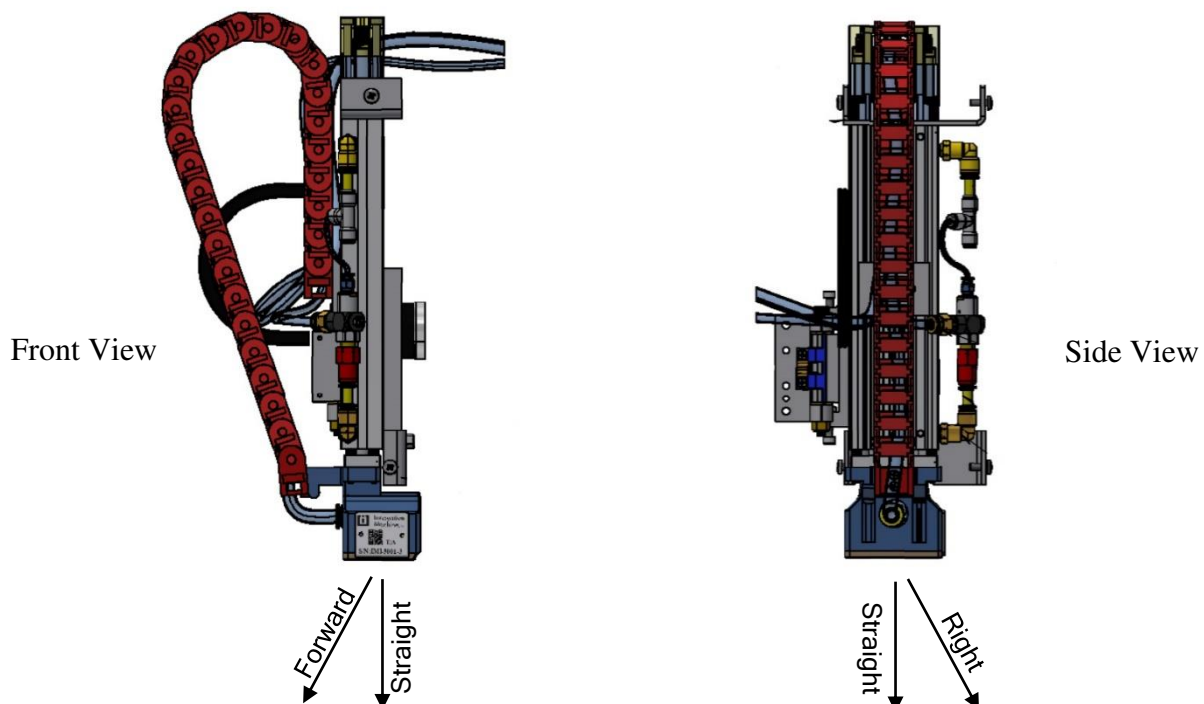

Proper Label Feed Position

Setting the Pitch and Offset for Label Position

The pitch will adjust where the text is on the label. If the text is not centered on the label, the print engine may double feed labels. See below for examples of good and bad pitch position.

Bad - High

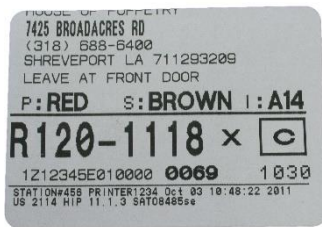

Good Pitch

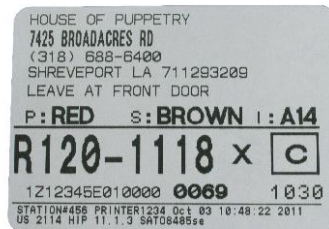

Bad - Low

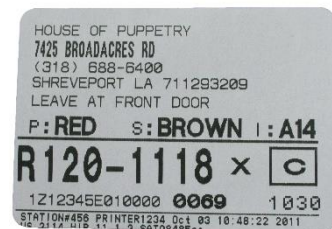

The label offset will affect how the label is printed and applied to a package. If there is too little or too much label queued over the dispense/peel bar, it is important to adjust the offset. See below for examples of good and bad offset position. *Please note that the pictures below will not happen in normal operation as the next label is pulled back into the print engine to increase speed. You will need to watch as you feed multiple labels to see how far the next label is presented on the dispense/peel bar before it is pulled back.* For instructions on how to adjust the offset, please view the **Offset Adjustment** video or **Inconsistent Label Presentation Causing Mislabels and Misfeeds** document on the support webpage.

Bad – Too Little

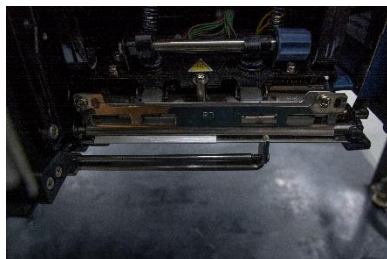

Good Offset

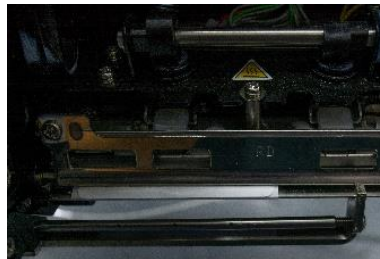

Bad – Too Much

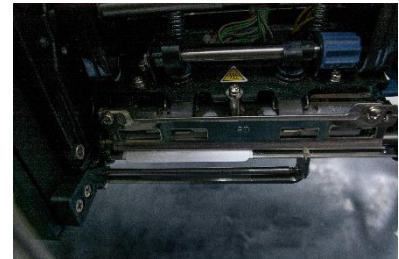

Troubleshooting using the HMI

The HMI has a maintenance section that can help with troubleshooting problems and other functions that are only used during commissioning or IMI assisted troubleshooting the machine.

Home Screen Default

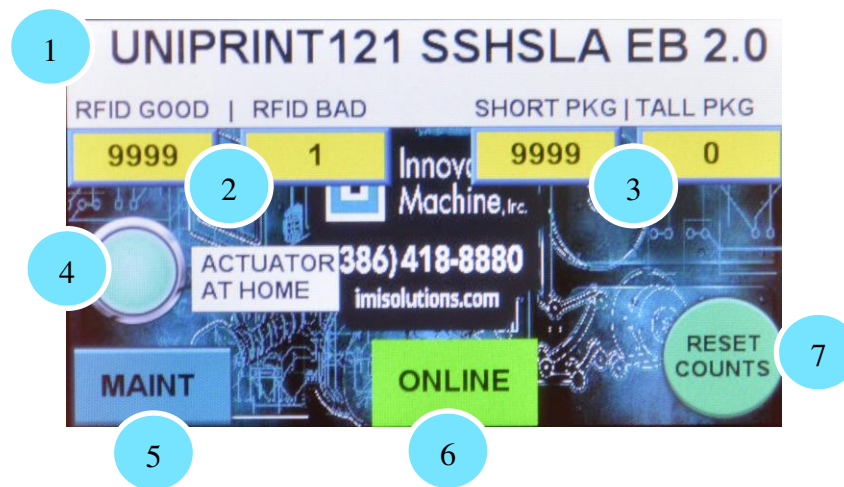

1. Model specific header for the Uniprint121EB SSHSLA.
2. RFID encoded and not-encoded counts
3. Package count
4. On when the Actuator is at home.
5. Used to access the Maintenance screens. A password is required to access this.
6. Press for Online or Offline mode. Must be in Online mode to function correctly.
7. Press to reset all counts on this screen.

Maintenance Access Menus

After pressing the “Maint” button on the “Home Screen”, you will be presented with the “Password” screen as shown to the right. To enter the password, press the button/field in the middle of the screen and an entry screen will be displayed. Enter 2123. If after entering the password the “Password” screen is still shown, press the button on bottom of the screen to close it. If all was entered correctly you should see the maintenance screen shown below. If not, please try the process again.



Please note that the Timer Menu, Apply Menu, OPS Menu, and Delay Capture are used during commissioning or IMI assisted troubleshooting.

Bypass Function Screen

By pressing the “Bypass Menu” button on the maintenance screen the following screen will be displayed.

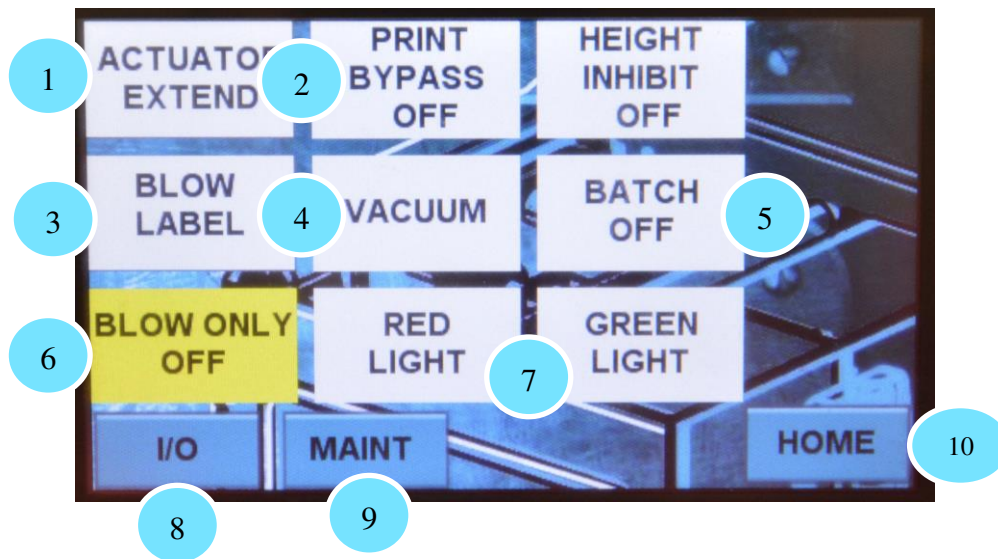

With the exception of the buttons 1 and 3, all others toggle the function on then off by successive presses. By pressing the buttons, you will...

1. Extend and retract the Actuator.
2. Bypass the actuator home sensor and allow a label to dispense for testing.
3. Blow air from the blow head.
4. Turn on the label vacuum.
5. Turn on Batch mode which bypasses the external apply signal.
6. Enable blow only (Pre-trip). ***The actuator will not extend with this enabled.***
7. Activate either the red or green lights on the light tree.
8. Return to the I/O menu.
9. Return to the Maintenance menu.
10. Return to the Home screen (exiting maintenance)

Certain functions when enabled will trigger the red light and audible to alert the operator. On the Home Screen there will be a notification(s). Pressing the notification will disable that function and the notification will disappear. If there are no other enabled functions, the red light and audible will stop.



I/O Screen

By pressing the “I/O Menu” button on the maintenance screen the following screen will be displayed.

Please note that this screen shows active states of the Inputs and Outputs only. There is no direct access to activate from this screen. Some I/O activate and deactivate so quickly that it may not be displayed long enough to be displayed on this screen.

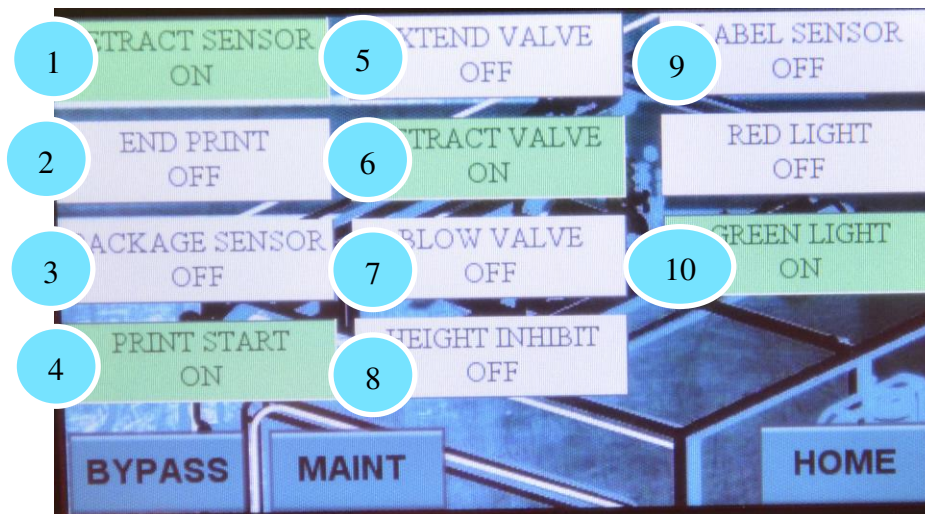

1. Should be Active if online and not extending.
2. Active only during printing
3. Active while the package sensor is above the preset gain
4. Active when online and not extending
5. Active when extending (only short burst)
6. Active when online and not actuating
7. Active when blowing a label (very short burst)
8. Active as required from PS Panel
9. Active when label on head sensor is covered
10. Active if online and no errors

New Machine Checklist

The following checklist should be completed once a machine is installed from the manufacturer/integrator:

1. Verify all connections:
 - Power
 - Air
2. Verify the machine is properly secured to the stand.
3. Ensure all components power on properly.
 - Power switch is switched to the on position.
 - S84 print engine is powered on.
 - Initial air charge should be heard until the print engine boots.
 - Verify 80 psi on regulator.
 - Print engine LCD screen should display “ONLINE”.
 - Opening the print engine door should generate an alarm (3 beeps should be heard), and an error message should be displayed on the machine’s HMI.
 - Verify that all print engine label feed heads (tracking, print head and pressure roller) are secured.
 - Once printer engine door is closed, the LCD screen should display “OFFLINE”, and the error on the machine’s HMI will no longer be displayed.
4. Verify all idle rollers spin freely and are free of residue.
5. Properly load a roll of labels. Check that the feed path is clear of debris and residue.
 - Verify the label guide is touching the label liner. It should not distort the liner.
 - Once labels are loaded, press the “FEED” key on the print engine to present a label onto blow head.
 - Feed 10 labels onto the blow head to ensure proper label alignment.
 - The 11th label should be square and centered on blow head.
6. Test the label blow pattern by putting the machine in maintenance mode.
 - On the print engine, press the “FEED” key to feed a label onto the blow head and blow the label onto a test box. The labels should stack on top of each other on the test box.
7. Test the machine by running a stress test of 25 packages to verify it is communicating and performing correctly.

General Maintenance

CAUTION: Before maintenance is started, ensure that both the electrical and pneumatic lockout/tagout (LOTO) has been carried out.

Proper Cleaning Supplies

- Denatured Alcohol
 - [View SDS for Denatured Alcohol](#)
- Microfiber Cloth
- Sato EZ Wipes
 - [View SDS for EZ Wipes](#)

Frequency of maintenance

- Clean the machine before and after every sort.

Cleaning includes (recommended daily)

- Label stock should be removed from each machine after every sort and stored in an air conditioned environment.
- Use denatured alcohol with a microfiber cloth or Sato EZ Wipes to clean the following components:
 - Rollers
 - Label guide
 - Gap sensor's black segmented rollers
 - Gap sensor window
 - Print plate/head
 - Pressure/Knurl roller assembly
 - Blow Head/Actuator Assembly

Compressed air can also be used to remove slitter dust from the machine. If you do not use denatured alcohol or EZ wipes there will be a build up of label residue on key components that will affect the application process.

Decommissioning and Disposal

When the machine has reached the end of its life cycle, care should be taken to decommission and dispose of it.

Decommissioning involves disconnect the machine from the source and cutting all pneumatic hoses and electrical conductors. This is done to ensure that the machine is inoperable.

When disposing of the machine, it should not be treated as household waste. Disposal of any hazardous substance and/or electrical/electronic components should be in accordance with National regulations of the end user (e.g., the re-cycling of components, sub-assemblies and the equipment itself).

Troubleshooting/Support

Our [UPS Support](#) website provides documentation, videos, interactive spare parts, and FAQs to help with general maintenance and troubleshooting. If any issues are not answered after viewing the webpage, please contact our office by calling **(386) 418-8880** or emailing **support@imisolutions.com**. Technicians may ask for videos or photos of the issue to be sent in to better identify the problem.

Full machines, print engines, and/or actuators may be sent to our repair department to be serviced. Please follow the instructions on the [UPS Repair Process](#) webpage to send in units.

Spare Parts

UniPrint121EB SSHSLA Spare Parts List

Coupa Number	Description	Recommended Qty
7187257	UniPrint121EB SSHSLA (I) Machine (Includes Actuator Cover and Roll Feed Adaptor)	1
7187615	UniPrint121EB SSHSLA (O) Machine (Includes Actuator Cover and Roll Feed Adaptor)	1
7187268	SKB Molded Ship Crate for UniPrint121EB SSLAW/SSHSLA Models	1
7187271	IMI Machine Cover for all UniPrint Models	1
7187286	IMI Tool Kit	1
7186057	EZ Wipes for Cleaning/Maintenance	1
7187355	Air Assist Rod for UniPrint Models	1
7187357	Bearing Block Pulley (Large) for SSLAW/SSHSLA and ALA Models	1
7187368	Motor Pulley (Small) for SSLAW/SSHSLA and ALA Models	1
7187250	Take-Up Drive Belt for All UniPrint Models	1
7187384	Take-Up Motor Assembly for All UniPrint Models	1
7187272	Take-Up Pin Holder for SSLAW/SSHSLA and ALA Models	1
7187316	Take-Up Spring Assembly for All UniPrint Models	1
7187374	Take-Up Sensor for All UniPrint Models	1
7187287	Spring Plungers (Pack of 2) for UniPrint121EB Actuators	1
7187378	Amplifier for UniPrint121EB Models	2
7187293	Fuse Pack (1, 2, 7.5 AMP) for UniPrint121EB Models	1
7187292	Belt/Fuse/Screw Pack for UniPrint121EB Models	1
7187394	UniPrint121EB Main PCB Board	1
7187550	Actuator Assembly for UniPrint121EB SSHSLA Models (Inside)	1
7187551	Actuator Assembly for UniPrint121EB SSHSLA Models (Outside)	1

S84-ex Specific Parts

7187259	LH S84NX RFID Print Engine for UniPrint121EB SSHSLA (Ethernet) Models	1
7187295	Stage 1 Kit LH for S84-ex LH Print Engines	1
7187299	Stage 2 Kit LH for S84-ex LH Print Engines	1
7187310	Tracking Collar for S84ex Print Engines	1

S84NX Specific Parts

7187677	LH S84NX RFID Print Engine for UniPrint121EB SSHSLA (Ethernet) Models	1
7187471	Stage 1 Kit LH for S84NX LH Print Engines	1
7187472	Stage 2 Kit LH for S84NX LH Print Engines	1

Support Links for All UniPrint Models

Scan the QR code with your phone/tablet or click the model.

UniPrint109

[HSLA](#)



[SSLAW](#)



UniPrint116

[HSLA](#)



[SSLAW / SSHSLA](#)



UniPrint121EB

[ALA LH / RH](#)



[SSLAW / SSHSLA](#)



121EB SSSSLA 2.0 Wiring Diagram

[Click here to view Online](#)

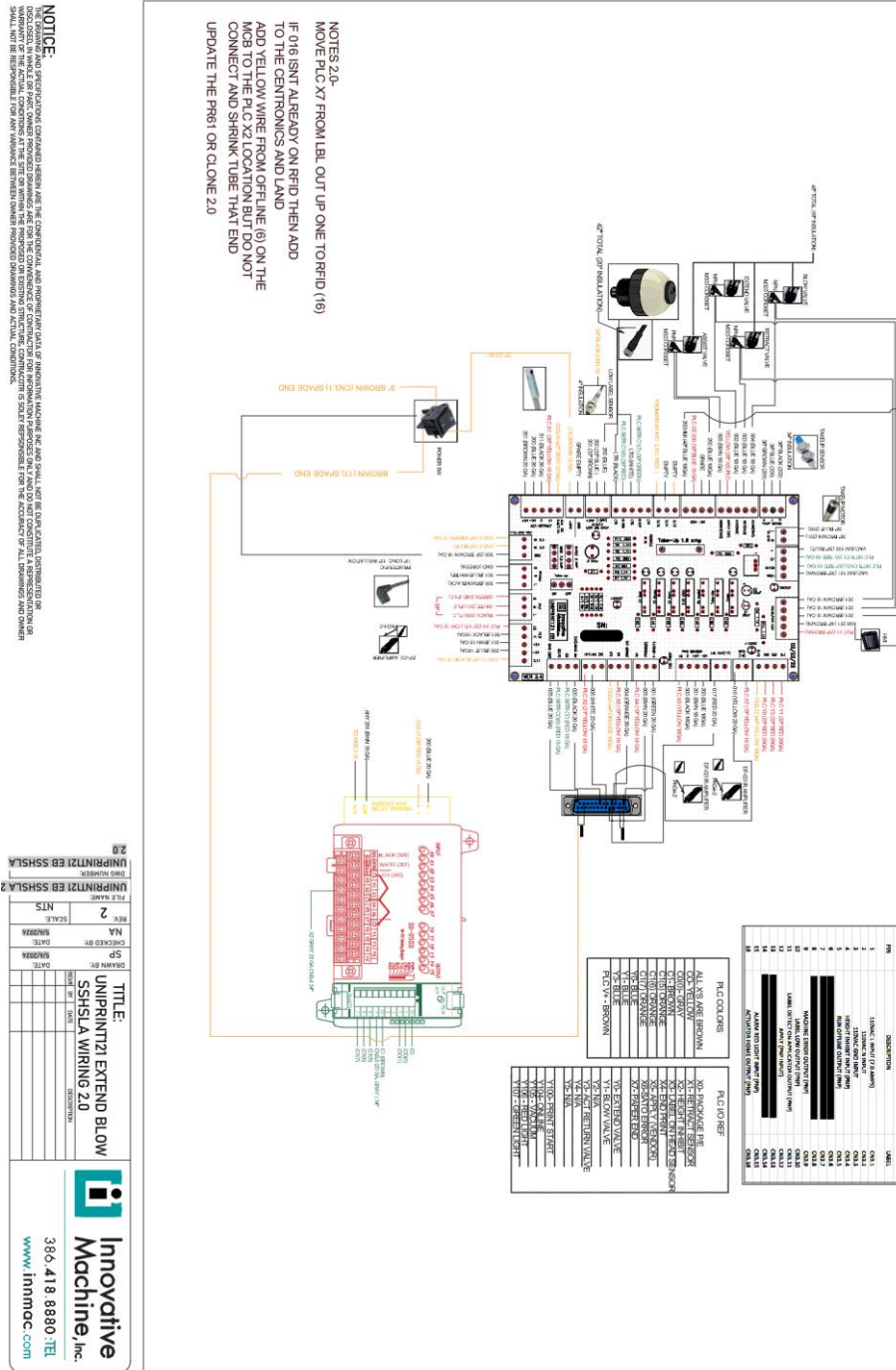

Declaration of Conformity Example

UK/EC DECLARATION OF CONFORMITY



Manufacturer Business Name & Full Address

Innoivative Machines Inc.
6115 NW 123rd place
Gainesville
FL 32653
USA

European Authorized Representative

Hold Tech Files Ltd
Dun Iseal, Newtown, Gaulsmill
Ferrybank, Waterford
X91F638
Republic of Ireland

Person Authorized to Compile the Technical File Name & Address:

Hold Tech Files Ltd Dun Iseal, Newtown, Gaulsmill, Ferrybank, Waterford, X91F638 Republic of Ireland

Machine Details

Model: Uniprint121EB SSLAW

Description: Printer and Label application

Serial #: XXXXXXXXX

Electrical Information: 230 Vac Single Phase 50Hz + PE

I declare that the machinery fulfils all the relevant provisions of these UK Regulations: Supply of Machinery (Safety) Regulations 2008 as amended and the Electromagnetic Compatibility Regulations 2016 as amended, and these European Directives: Machinery Directive 2006/42/EC and Electromagnetic Compatibility Directive 2014/30/EU.

BS EN ISO/IEC Standards Used

BS EN ISO 4414:2010; BS EN ISO 11201:2010; BS EN ISO 12100:2010; BS EN ISO 13849-1:2015; BS EN ISO 13857:2019; BS EN ISO 14118:2018; BS EN ISO 14120:2015; BS EN 55011:2016+A2:2021; BS EN 60204-1:2018; BS EN 61000-4-2:2009; BS EN IEC 61000-4-3:2020 and BS EN 61000-4-4:2012

The Technical documentation is compiled in accordance with Annex VII of the Machinery Directive.
The Technical File provides evidence of conformity of the machine with the essential requirements of the Directive.

Place of Declaration

Innoivative Machines Inc.
6115 NW 123rd place
Gainesville
FL 32653
USA

Date of Declaration: Leave blank (Do not date)

Person empowered to draw up Declaration

Name: Shawn Poole

Position: Vice President

Signature: Do not sign _____



Original Declaration

